



Ergonomic packing and workplace systems
Cutting systems for packing materials
Custom solutions



ROCHOLZ
HR-PACKTISCHE

Selection guide

	BASIC	SYSTEM 1200/1600	SYSTEM 2000	SYSTEM FLEX	SYSTEM FLEX LIGHT	MODUL 5000
Flexibility is important to us, it should be easy to adapt the table to accommodate future processes.	●●●●	●●●●	●●●●	●●●●	●●●●	●●●●
Ergonomics at the workplace are a key issue for us.	●●●●	●●●●	●●●●	●●●●	●●●●	●●●●
The design and look of the table are crucial aspects for us.	●●●●	●●●●	●●●●	●●●●	●●●●	●●●●
We attach great value to an extensive range of accessories with numerous shelves, PC solutions, etc.	●●●●	●●●●	●●●●	●●●●	●●●●	●●●●
Our packing tables are used for shift work or several people share them at any one time.	●●●●	●●●●	●●●●	●●●●	●●●●	●●●●
Our requirements are extremely complex. In some areas we will definitely require custom solutions.	●●●●	●●●●	●●●●	●●●●	●●●●	●●●●
A packing table that just offers the main functions is all we need. The solution must be inexpensive.	●●●●	●●●●	●●●●	●●●●	●●●●	●●●●
We want to make a quick decision. Do you have complete, pre-configured packing tables?	●●●●	●●●●	●●●●	●●●●	●●●●	●●●●

Protect Yourself and Your Surroundings
Download our hygiene flyer here:



PRODUCT DIVERSITY

Your idea is our mission	Pages 2 - 5
What role do ergonomics play at the workplace?	Pages 6 - 7
SYSTEM BASIC The practicable solution	Pages 8 - 13
SYSTEM 1600 Compact packing stations Inexpensive and compact	Pages 14 - 15
SYSTEM 2000 The systematic solution	Pages 16 - 43
SYSTEM FLEX Combine the possibilities	Pages 44 - 63
ASSISTANCE AND DOCUMENTATION SYSTEMS	Pages 68 - 69
INDIVIDUAL SOLUTIONS	Pages 70 - 71
MODUL 5000 The fantastic solution	Pages 72 - 86
MODUL 5100 + MODUL 5200 Work standing up or sitting down	Pages 87 - 89
CUTTING SYSTEMS Fast, safe, cost-saving	Pages 90 - 95
TRANSPORTING SYSTEMS Perfect addition to your workplace	Pages 98 - 99
ESD equipment	Page 100
Product features	Page 102

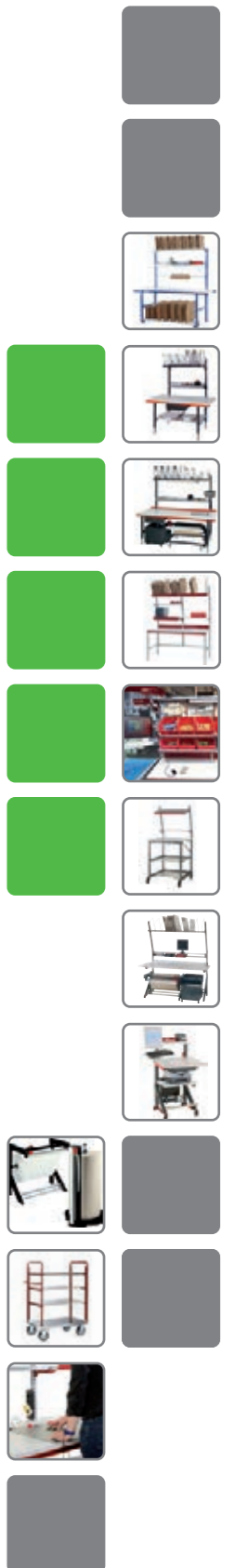

Your idea is our mission



Dear business partner,

we are delighted to present the current Rocholz catalogue! With this catalogue we would like to bring you up to speed on new developments and improvements we have introduced to our range, especially thanks to your suggestions.

Our SYSTEM FLEX in particular boasts new highlights: adaptable roller track tables as a connection to the conveyor system, an extensive range of hooks for the perforated back panels and new LED workplace lighting that can be attached directly to the shelves. Transporting devices are an entirely new feature, completing our logistics range and guaranteeing a seamless flow of materials and an effective optimisation of your processes.

Our product updates allow you to work even more efficiently and ergonomically: it's no coincidence that our SYSTEM FLEX has been

IGR-certified as ergonomic! (As the first packing table worldwide!)

We also organise our internal procedures with our philosophy of efficiency – we use an ISO 9001:2015 certified management system and progressive, eco-friendly technologies at our production site in Germany, aiding the premium quality you will witness on the following pages. It is our goal to inspire you with our products and our service. We always want to offer you the most efficient solution and therefore also design bespoke systems to fit your individual needs.

Get in touch with us to explore your potential for efficiency!

We look forward to working with you!

Kind regards
Marc Rocholz

Successful teamwork!

Together with your local dealer, we will help you to bring your project to fruition, beginning at the planning phase, through to the realisation, and finishing with the installation at your premises. Benefit from our long-standing experience and expertise.

The workplace plays a determining and often underestimated role when it comes to productivity and optimising processes.

A dedicated department with extensive project experience makes sure, together with the local distributor, that the packing workplaces are not only ideally integrated into the product flow, but also that they satisfy ergonomic standards.



It is possible to lower processing times and increase order picking or packing output by around 20% through effective integration of the workplaces in the product flow, and by taking the downstream and upstream processes into consideration.

Ergonomics at the workplace

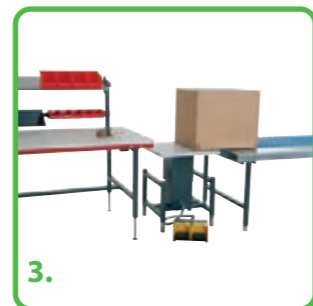

Ergonomics at the workplace

Investing in an ergonomically designed workplace will benefit both your employees' health and the efficiency and quality of the work they do. On average, employees are absent from work due to illness on around 12 days every year. If this downtime could be reduced by just 3 days with a sensibly designed workplace where ergonomics are concerned, that would equate to annual cost savings of about €1,000 with each employee. The consequent increase in productivity can very quickly accumulate up to an additional €800-1000 per person and year. Your investment in an ideal packing table can therefore pay for itself in just 1 to 2 years.

Solutions for a healthy workday

Industrial safety regulations prescribe basic safety measures to be observed when using work equipment. We will help you to put these regulations into practice.

§ 6 Grundlegende Schutzmaßnahmen bei der Verwendung von Arbeitsmitteln

(1) Der Arbeitgeber hat dafür zu sorgen, dass die Arbeitsmittel sicher verwendet und dabei die Grundsätze der Ergonomie beachtet werden. Dabei ist Anhang 1 zu beachten. Die Verwendung der Arbeitsmittel ist so zu gestalten und zu organisieren, dass Belastungen und Fehlbeanspruchungen, die die Gesundheit und die Sicherheit der Beschäftigten gefährden können, vermieden oder, wenn dies nicht möglich ist, auf ein Mindestmaß reduziert werden. [...]

1. die Arbeitsmittel einschließlich ihrer Schnittstelle zum Menschen müssen an die körperlichen Eigenschaften und die Kompetenz der Beschäftigten angepasst sein sowie biomechanische Belastungen vermeiden. Zu berücksichtigen sind hierbei die Arbeitsumgebung, die Lage der Zugriffstellen und des Schwerpunktes des Arbeitsmittels, die erforderliche Körperhaltung, die Körperbewegung, die Entfernung zum Körper, die benötigte persönliche Schutzausrüstung sowie die psychische Belastung der Beschäftigten,

2. die Beschäftigten müssen über einen ausreichenden Bewegungsfreiraum verfügen,

Figs. 1-4 Pneumatic lift table: Do you want to effortlessly lift or lower heavy packaging items and get them into the right gripping or working height? If so, the pneumatic lift table is just what you need, and it's also the ideal solution as an interface to the flow of materials.

Fig. 5 Inclined mounting profiles and sloping shelves support ergonomic movement at the packing station.

Fig. 6 Height adjustment with a folding crank - 710-960 mm: easily adjust the table to the right working height.

Fig. 7 Electrical height adjustment - 710-960 mm: featuring four saved settings and a height display, the table can be variably positioned to suit each employee.

Fig. 8 Workplace mats: These protect the joints and spinal discs, are slip-resistant, and offer sure footing at the workplace. The special structure of the underside of the workplace mats also means that the body stays in motion. This is good for the circulation, prevents fatigue, and reduces strain on one side of the body. Other versions are also available for entire aisles and are, as you would expect, suitable for use with pallet trucks.

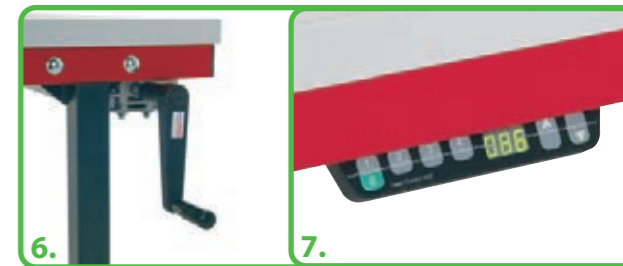

Ergonomic Product

Certificate

The IGR Institute certifies that the test has been passed

Rocholz GmbH
Neuwegstraße 240-242
42553 Velbert

SYSTEM FLEX

The test carried out by the Institut für Gesundheit und Ergonomie e.V. (IGR e.V.) confirms the usability and ergonomics of the product. The tests are based on the specifications of the standards DIN 33 419 / EN ISO 15537. The examination investigated the degree of adaptation of the product to the physical characteristics of the test subjects.

IGR Institut für Gesundheit und Ergonomie

IGR e.V. – Vorstand
Nuremberg, 01 May 2016



We're delighted to present the very first* packing table to have been certified by the IGR as being an ergonomic product. The SYSTEM FLEX creates the perfect conditions at the workplace for working economically, healthily and efficiently.

If you want to learn more about ergonomics in the workplace ask our ergonomics brochure.

PRACTICABLE



Bottom shelf

Add-on storage rack

Upright

Side table

Cupboard unit



The overhauled SYSTEM BASIC is the inexpensive entry-level system for the packing world. Limited to the main components, SYSTEM BASIC offers a budget table without having to sacrifice stability.

SYSTEM BASIC



Visit
www.huedig-roholz.de
for more product illustrations.



PRACTICABLE

Reduced to the basic essentials!
The SYSTEM BASIC offers all the main functions at an attractive price.

SYSTEM BASIC

The solution for application areas where every euro counts. This packing table meets the same demanding quality expectations we ourselves place in our products. It has a working height of 850 mm, which can naturally be adjusted as required.

- Sturdy steel table with integrated bearing shells for holding a material roll shaft
- 19 mm worktop
- 100 kg surface load capacity
- Melamine resin-coated worktop
- Galvanised steel shelves
- Cutter with titanium-coated blade
- IT accessories for PC, monitor and keyboard
- Powder-coated steel parts: gentian blue RAL 5010

NEW features:

- Add-on storage rack made of square tubing
- Lockable drawer made of sheet steel
- Undertable cardboard storage rack made of square tubing
- Galvanised steel side table
- Galvanised steel backboard
- BASIC cutter stand for paper, foam and air bubble film
- Spindle for roll material above or underneath the table

 **QUALITY
MADE
IN GERMANY**

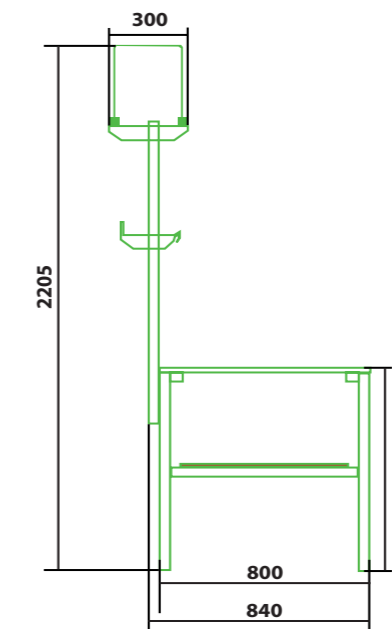
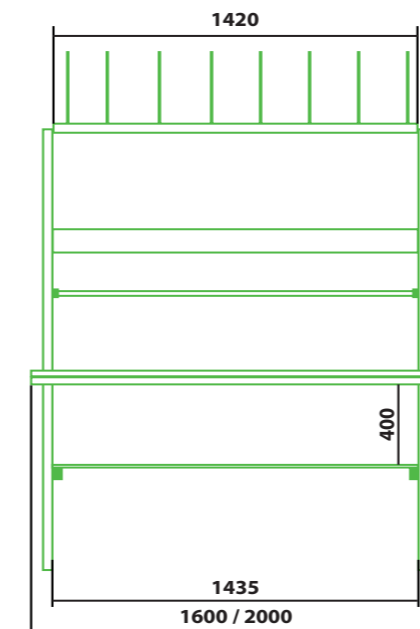

Aller Maßeangaben in mm



Our range of accessories offers numerous expandability options. Extra shelving, IT accessories, drawers, containers, as well as mobile cupboard and drawer units. Detailed information can be found on the following pages.

Plan and design SYSTEM BASIC



SYSTEM BASIC packing and work table

- Sturdy steel construction
- Struts and legs made of square tubing
- Melamine resin-coated 19 mm table top
- Max. surface load 100 kg

Order no.	W x D x H (mm)
700001	1600 x 800 x 850
700002	2000 x 800 x 850



Add-on storage rack

- Square tubing
- Incl. 8 dividers
- Max. surface load 50 kg
- Weight 19 kg

Order no.	W x D x H (mm)
700050	1420 x 300 x 400



Drawer

- Made of sheet steel
- Lockable
- Load capacity 12.5 kg

Order no.	W x D x H (mm)
700120	513 x 530 x 160



Uprights

- For any combination of table accessories
- 1 set = 2 pcs.
- Height above table 1030 mm, slots every 200 mm

Order no.	W x D x H (mm)
700030	40 x 40 x 1266

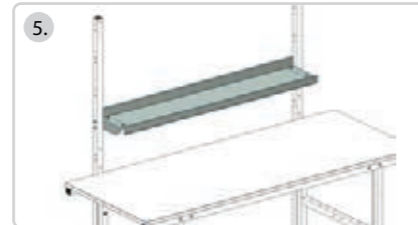

Document shelf

- Galvanised sheet steel for attachment to uprights
- Max. surface load 50 kg
- Weight 6 kg

Order no.	W x D x H (mm)
700060	1425 x 253 x 114



Container

- Mobile with 4 castors
- 2 lockable castors
- Load capacity 50 kg
- Sturdy plastic
- Weight 7 kg

Order no.	W x D x H (mm)
700110	610 x 416 x 495



Bottom shelf

- Melamine resin-coated 19 mm sheet
- Max. surface load 50 kg
- Weight 19 kg

Order no.	W x D x H (mm)
700100	1525 x 650 x 19



Storage shelf

- Galvanised sheet steel for attachment to uprights
- Max. surface load 25 kg
- Weight 15 kg

Order no.	W x D x H (mm)
700070	1430 x 400 x 58



Drawer unit

- Sheet steel
- Mobile with 4 castors
- 2 lockable castors
- Four drawers
- Load capacity 35 kg per drawer
- Weight 42 kg

Order no.	W x D x H (mm)
3010	490 x 600 x 675



Cupboard unit

- Sheet steel
- Mobile with 4 castors
- 2 lockable castors
- With 1 drawer and 1 cupboard door
- Load capacity 50 kg
- Weight 32 kg

Order no.	W x D x H (mm)
3011	490 x 600 x 675



Add-on cutter

- For attachment to uprights
- Cutting width 1250 mm
- Incl. shaft
- Galvanised
- Weight 12 kg

Order no.	W x D x H (mm)
700090	1500 x 175 x 20

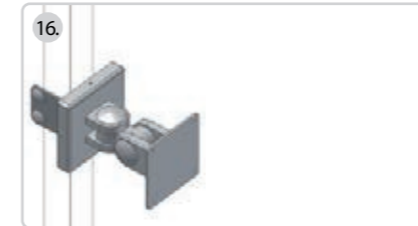

Screen holder, Vesa 75/100

- Incl. adapter for Vesa 75 and Vesa 100
- Weight 0.5 kg

Order no.	W x D x H (mm)
228120	200 x 100 x 100



Spindle between the uprights

- For mounting material rolls max. Ø 300 mm
- Load capacity 20 kg

Order no.	W x D x H (mm)
700140	1425



Undertable cardboard storage rack

- Square tubing
- Mobile with 4 castors
- 2 lockable castors
- Incl. 8 dividers
- Surface load 50 kg
- Weight 14 kg

Order no.	W x D x H (mm)
700080	1415 x 300 x 415



Backboard

- For attachment to uprights
- Sheet steel
- Galvanised
- Weight 2 kg

Order no.	W x D x H (mm)
700040	1515 x 4 x 70



Cutter stand

- Horizontal
- With blades for foam, air bubble film, etc.
- Cutting width 1250 mm
- Max. roll weight 50 kg
- Max. roll diameter 1000 mm

Order no.	W x D x H (mm)
700130	1500 x 920 x 1100



Spindle underneath the table (between feet)

- For mounting material rolls max. Ø 750 mm
- Load capacity 100 kg

Order no.	W x D x H (mm)
700150	1430



Side table

- Square tubing
- Sheet steel table top
- Galvanised
- Max. surface load 100 kg
- Weight 20 kg

Order no.	W x D x H (mm)
700020	600 x 600 x 750



PC holder with strap

- For securing the PC underneath the table
- Weight 1 kg

Order no.	W x D x H (mm)
308100	Umkreis max. 1680



The different components of SYSTEM BASIC allow you to design an individual workplace.

Experience shows that many needs can be covered by our basic system. And the attractive price means that it will quickly pay for itself!



Document shelf

Steel drawer



On page 90 you will find some interesting facts about the add-on cutter!

SYSTEM 1600

Complete packing station with 1600 mm wide table top, document shelf and cardboard storage rack

- Sturdy steel table
- 30 mm worktop
- 300 kg surface load capacity
- Light grey worktop coated with melamine resin
- Steel components with powder-coated finish, anthracite RAL 7016, ruby red RAL 3003

Order no. 163001

W x D x H (mm): 1600 x 800 x 690-960

With bottom shelf (1145 x 650 x 19 mm) and steel drawer (520 x 500 x 150 mm)

Order no. 163002

W x D x H (mm): 1600 x 800 x 690-960

Like 163001 but with cutter in silver-grey RAL 9007, cutter cartridges for paper and foils, cutting width 100 cm, spindle set with cones and bearing shells (without drawer and bottom shelf)

QUALITY MADE IN GERMANY

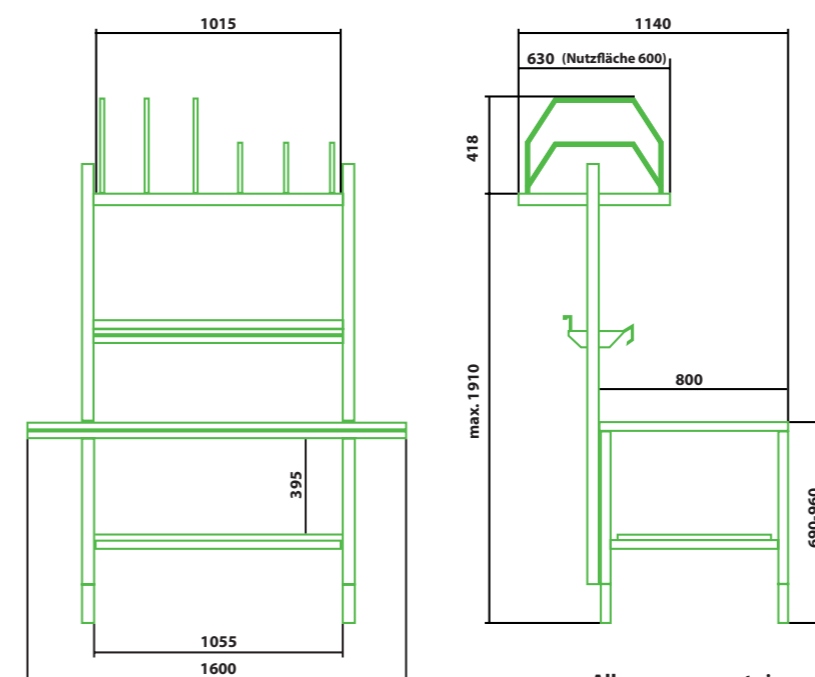

All measurements in mm

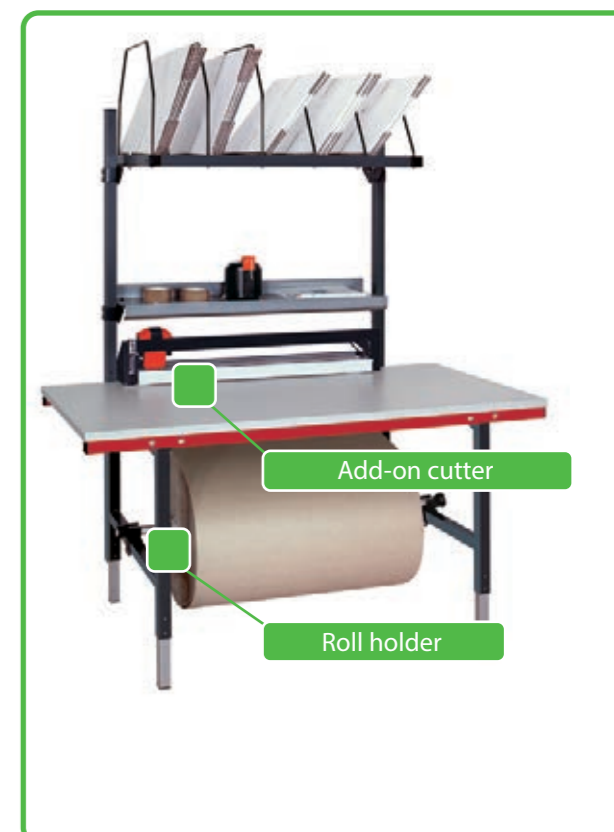

SYSTEMATIC

SYSTEM 1600 offers you two all-in-one solutions with either a bottom shelf and steel drawer, or with a roll holder and add-on cutter - depending on what it is to be used for.

Do you need other accessories? That's no problem, as both all-in-one solutions can be extended with accessories from the SYSTEM range. You can also put together your own custom solution from the SYSTEM 1600 elements shown on the following pages. The SYSTEM 1600 has an adjustable height of between 690 mm and 960 mm as standard.



The add-on cutter is supplied with two cutter cartridges. The smooth blade is for cutting foil and the round serrated blade is for paper and cardboard. The cartridges can be effortlessly replaced.

SYSTEMATIC



A suitable solution for every requirement. The extensive range of accessories offers unlimited scope for combinations. Here we can show you just a few selected extension options. Your local dealer will be pleased to advise you about putting together the best packing table for your own requirements.

SYSTEM 2000



You will find all our instruction manuals in the download centre at www.huedig-rocholz.de



SYSTEMATIC

Classics, bestsellers, standard - these are terms we hear time and time again in conjunction with our SYSTEM 2000. "Extremely versatile and long-lasting" - that probably sums it up. The SYSTEM 2000 offers a multitude of combination possibilities. Beginning with the various types of tables through to the extensive range of accessories and suitable cutter stands, the system offers the ideal solution for all your needs.



SYSTEM 2000

On the following pages we will show you several interesting solutions, regardless of whether you require a single, extremely efficient workplace, or you want to equip an entire logistics centre. Here you will find further information about ergonomics and our extensive range of IT accessories. Key aspects of consignment processes are the flow of materials and weighing, which naturally also includes our roller track tables.

- Sturdy steel table
- 30 mm worktop
- 300 kg surface load capacity
- Max. load capacity of lifting system 350 kg
- Light grey worktop, coated with melamine resin
- Steel components with powder-coated finish, anthracite RAL 7016, ruby red RAL 3003
- Optional height adjustment with a crank or electric motor
- Custom solutions as special designs
- Extensive range of accessories
- Flexible clamp mounting for accessories
- Tables with integrated scale and/or roller track

 **QUALITY
MADE
IN GERMANY**

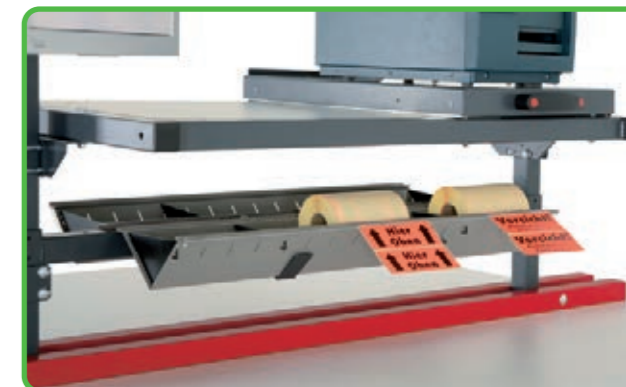
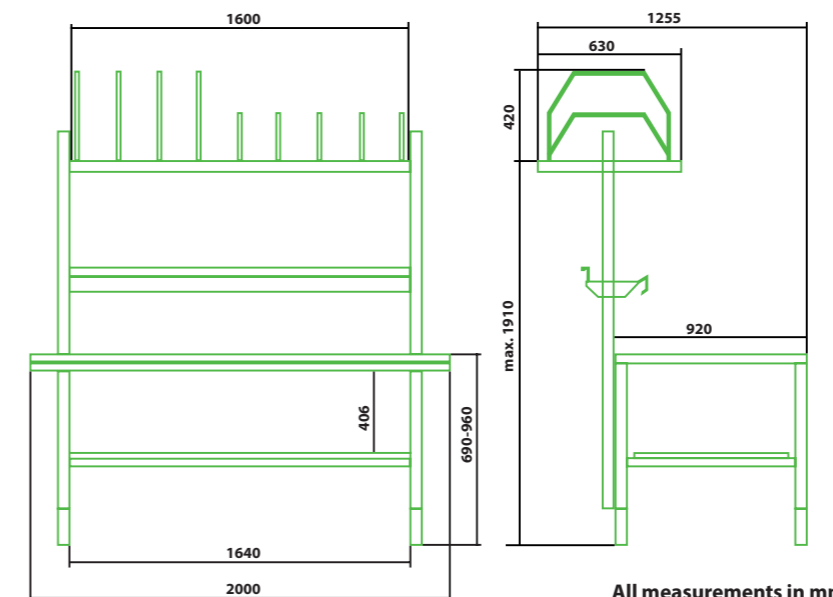

If the work surface is too large, over time all kinds of things accumulate on it which don't belong there.

Keep your workplace completely clear and orderly right from the outset with the appropriate accessories. This will save time and calm your nerves!

SYSTEM 2000

Special features at a glance:

- SYSTEM 2000 can be expanded or upgraded whenever the need arises. This means that your products keep flowing when processes and demands change. At the same time you get a high degree of investment security.
- Daisy-chaining, integration and adaptation options offer countless possibilities from single workplaces up to complete packaging lines.
- SYSTEM 2000 organises everything you need ergonomically and close at hand, creating a tidy and efficient workplace.
- SYSTEM 2000 is versatile, and can be supplied as a packing table, roller track table, with an integrated scale, as well as with various height adjustments.
- Custom solutions. Together with your local specialist trading partner, we can develop a custom solution with SYSTEM 2000 to meet your needs.



Alongside high quality standards, being located in Germany also means that we can guarantee short delivery times and efficiently supply accessories and spare parts.

Surfaces

It goes without saying that we can offer you the right worktop for every application. As well as mechanical strain and which transport containers are used, "soft" factors also play a role. We can fulfil your colour requirements as well as provide different woodgrain decors for a pleasant working atmosphere. For assembly work, for instance, we recommend a finger-jointed worktop. A brand new addition to the range is our cut-resistant surface, e.g. for cutting packing material to size at the workplace. Our melamine resin coating has proven to be a real all-rounder, which we supply as standard.

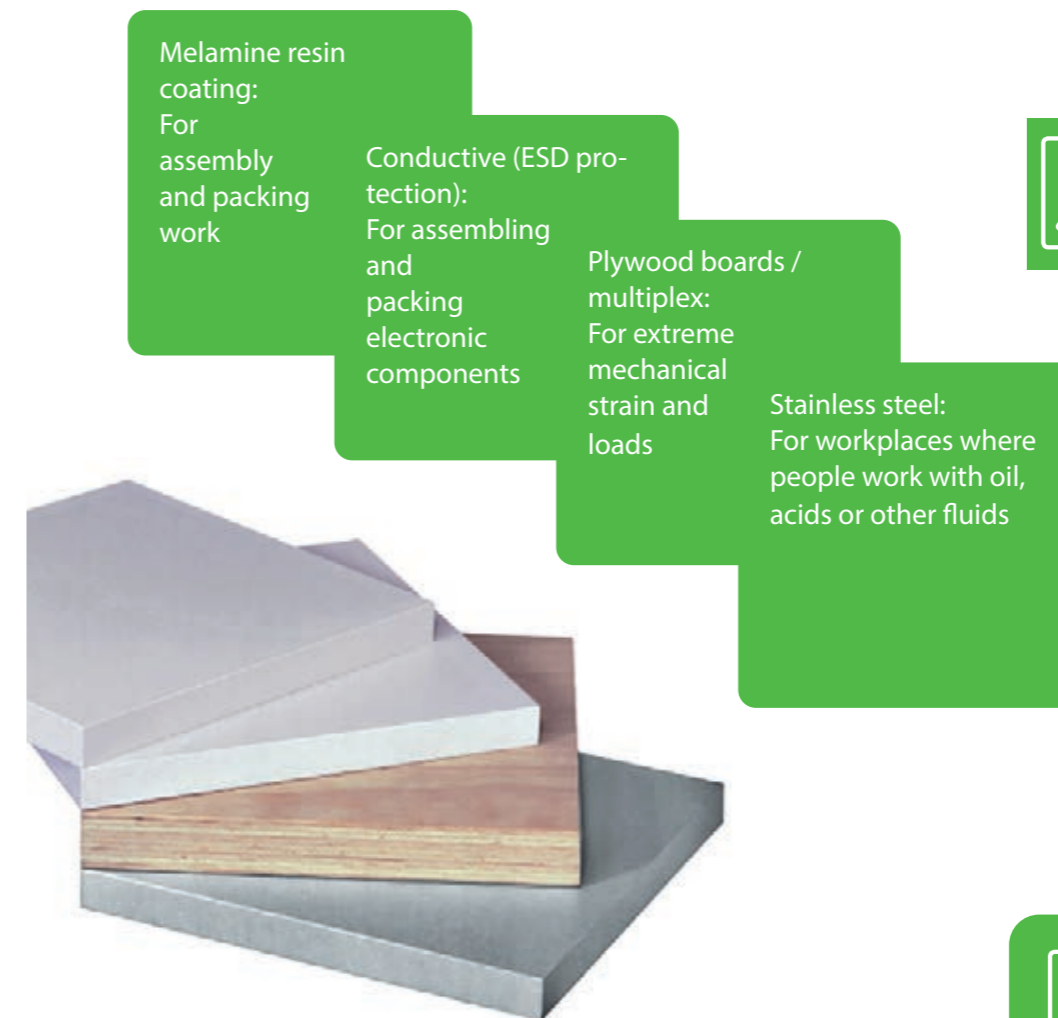

You can protect the table top with a cut-resistant surface! See page 42 for more details.



Choose your preferred surface from our range. You can also combine it with all the other packing table systems!

Not only that, but you can even choose your favourite accentuating colour! Discuss your requirements with our trained sales partners – we'll be glad to help you!

SYSTEM 2000



 From page 30, put together your custom SYSTEM 2000 to suit your needs!

SYSTEM 2000



Ergonomically integrated IT

- Holders for PCs, thin clients and notebooks
- Flexible monitor holders for different designs
- Ergonomic solutions for keyboard and mouse
- Printer platforms and trolleys for different printing systems
- Easy assembly
- Easy access for servicing
- Ongoing developments and adaptations to accommodate new technologies
- Other solutions available on request

Fig. A
The various screen folding arms, as well as the keyboard and mouse platform with folding arm, can be individually combined with the supporting column, upright adapters or profile rails. The fastening system allows monitors to be easily installed (they can be secured with fixing screws).

Fig. B
Retracting printer shelf for label printers: Allows you to easily replace the printing media. Simply pull the shelf with the printer towards you for convenient access to the labels (rolls) and printing foil.

Fig. C
Printer trolley: Sturdy and mobile steel design, ideal for larger laser printers with tray, e.g. for paper.



IT at the workplace

Today, IT is an indispensable element of most workplaces. That's why we have put together an especially extensive range of IT accessories for you. It includes holders for PCs and thin clients, various keyboard solutions such as the retracting keyboard drawer, or the folding keyboard tray, and monitor holders in different designs.



Proper positioning of IT components is easy with the special attachment options. But it also cuts down the workload for your IT support team since easy access is assured for reduced service downtimes.

SYSTEM 2000

- Maximum flexibility
The roller track table for SYSTEM 2000
- With work surface as a packing table
 - Without work surface as a transport/buffer table
 - Optionally available with integrated scale



Uninterrupted flow of materials

The flexibility of SYSTEM 2000 enables you to integrate it in your order picking and packaging processes. Various interface solutions, together with adaptation and integration options, assure an uninterrupted flow of products. One example of this are the weighing systems integrated in the table or roller track, as well as the ball units. The modular design means that adaptations can be made in the future with little effort and at a low cost. After all, it's not just the products that flow, but the processes as well.

With the right scale, you can do more than just weigh things!

With a scale, the first thing that springs to mind is weighing something. However, depending on the type of scale, it can do much more than just that. Counting scales, for example, can be helpful for order-picking small items or be used as "counting aids" in the incoming goods department. Linked to the ERP system or an article database recorded in the scale, weight plausibility checks can also be conducted during order picking. Supplemented by a barcode scanner and label printer, a large number of other solutions can also be realised. A suitable scale is available for every application purpose. Your specialist dealer will also consider this aspect during a personal consultation.



The scale can optionally also be positioned on the left or in the middle



Don't forget to take the upstream and downstream processes into account in your planning. How does the product get to the workplace, what's the next step? What happens with the empty transport containers, for instance?

SYSTEM 2000



Roller track tables

Roller track tables are the adaptive interface to the conveyor system and provide for smooth integration in the product flow. We can offer you different variations with and without a work surface, as well as with an integrated scale or height adjustment.

Flexible and versatile

Our roller track head table is especially interesting. On this table, the roller track element is rotated by 90 degrees, and both the height and the angle can be adjusted. This allows for both ergonomic positioning of the order picking container or packaging, as well as flexible integration in the product flow.

Our roller track tables are available in numerous combinations and designs:

- with and without work surface
- with integrated scale
- optional height adjustment with a crank
- roller track element parallel to the work surface or rotated by 90°
- adjustable angle on pure roller track tables
- suitable as a transport or buffer line
- custom solutions with rollers, small rollers or ball elements
- compatible with the accessories for SYSTEM 2000 work tables



360° view of the transverse roller track table at www.huedig-rocholz.de



We are constantly active, just like your processes! Safeguard your future with flexible, extendable and adaptable systems!

Tables SYSTEM 1200, SYSTEM 1600, SYSTEM 2000

All tables are also optionally available with multiplex or solid beech worktops



Packing and work table 1200

- Sturdy steel construction
- Struts and legs made of square tubing
- Foldable for transporting
- Melamine resin-coated 30 mm table top
- The accessories for table width 1600 can be used for this table width
- Max. surface load 300 kg

Order no.	W x D x H (mm)
123034	1200 x 800 x 690-960



Packing and work table 1600

- Sturdy steel construction
- Struts and legs made of square tubing
- Foldable for transporting
- Melamine resin-coated 30 mm table top
- Max. surface load 300 kg
- * Max. load capacity of lifting system 350 kg
- ** Speed of lifting system 30 mm/sec.

Order no.	W x D x H (mm)
163000	1600 x 800 x 690-960
163500 *	Adjustable height with crank 710-960 mm
163800 * **	Adjustable height electrical 710-960 mm



Packing and work table 2000

- Sturdy steel construction
- Struts and legs made of square tubing
- Foldable for transporting
- Melamine resin-coated 30 mm table top
- Max. surface load 300 kg
- * Max. load capacity of lifting system 350 kg
- ** Speed of lifting system 30 mm/sec.

Order no.	W x D x H (mm)
203000	2000 x 920 x 690-960
203500 *	Adjustable height with crank 710-960 mm
203800 * **	Adjustable height electrical 710-960 mm



Packing and work table with scale

- For non-legal-for-trade weighing, max. 60 kg
- Scale division 20 g
- Stainless steel platform
- With separate display unit
- Table as 203000
- * Max. load capacity of lifting system 350 kg
- ** Speed of lifting system 30 mm/sec.

Order no.	W x D x H (mm)
203200	2000 x 920 x 690-960 Weighing area 400 x 500 mm
203530 *	Adjustable height with crank 710-960 mm Weighing area 400 x 500 mm
203830 * **	Adjustable height electrical 710-960 mm Weighing area 400 x 500 mm



Packing and work table with scale

- Calibrating scale, PC interface, max. 60 kg
- Scale division 20 g
- RS232 interface
- Stainless steel platform
- With separate display unit
- Table as 203000
- * Max. load capacity of lifting system 350 kg
- ** Speed of lifting system 30 mm/sec.

Order no.	W x D x H (mm)
203210	2000 x 920 x 690-960 Weighing area 400 x 500 mm
203534 *	Adjustable height with crank 710-960 mm Weighing area 400 x 500 mm
203834 * **	Adjustable height electrical 710-960 mm Weighing area 400 x 500 mm



Roller track table with work surface

- Galvanised sheet steel work surface
- Work surface 1955 x 300 mm
- Roller width 600 mm
- Rollers 5 mm higher than work surface
- Max. surface load 150 kg
- * Max. load capacity of lifting system 350 kg

Order no.	W x D x H (mm)
203010	1955 x 920 x 690-960
203510 *	Adjustable height with crank 710-960 mm



Roller track table w/o work surface

- Struts and legs made of square tubing
- Standard height adjustment 690-960 mm
- Max. surface load 150 kg
- * Max. load capacity of lifting system 350 kg

Order no.	W x D x H (mm)
203020	1955 x 640 x 690-960
203520 *	Adjustable height with crank 710-960 mm



Roller track table w/o work surface, with scale

- For calibrating scale (PC interface) or non-legal-for-trade weighing, max. 60 kg
- Scale division 20 g
- With separate display unit
- Max. surface load 150 kg
- * Max. load capacity of lifting system 350 kg

Order no.	W x D x H (mm)
203021	1955 x 640 x 690-960 Weighing area 600 x 600 mm
203521 *	Adjustable height with crank 710-960 mm
203022 calibrating scale	1955 x 640 x 690-960 Weighing area 600 x 600 mm
203522 * calibrating scale	Adjustable height with crank 710-960 mm



Roller track table with work surface and scale

- For legal-for-trade or non-legal-for-trade weighing, max. 60 kg
- Scale division 20 g
- With separate display unit
- Max. surface load 150 kg
- * Max. load capacity of lifting system 350 kg

Order no.	W x D x H (mm)
203011	1955 x 920 x 690-960 Weighing area 600 x 600 mm
203511 *	Adjustable height with crank 710-960 mm
203012 legal-for-trade	1955 x 920 x 690-960 Weighing area 600 x 600 mm



Side guard for roller track tables

- Limiter for safely guiding packages and packing items on the roller track

Order no.	W x D x H (mm)
203540	1955 x 20 x 70



End stop for roller track tables

- Limiter for packages and packing items on the roller track

Order no.	W x D x H (mm)
203541	600 x 10 x 100



Locking plate

- for roller track tables with a roller track width of 600 mm + 75 division
- galvanised surface

Order no.	W x D x H (mm)
203544	600 x 125 x 62,5

The scale can optionally also be positioned on the left or in the middle!
The scale display unit can be attached to a separately available bracket (p. 39).



The uprights or mounting frame form the basis for all accessories fitted above the table (pages 32). Please also note that suitably sized accessories are available for table widths 1600 and 2000. Your local dealer will be pleased to advise you about putting together the best solution for your own requirements.

SYSTEM 1200, SYSTEM 1600, SYSTEM 2000
Which upright fits which table?

Mounting upright	2062	2064	2065	2066	206411	206410
Packing table						
123034, 163000	●	●			●	
163500, 163800			●	●	●	
203000, 203200, 203210	●	●				●
203500, 203532, 203533, 203800, 203832, 203833, 203530			●	●		●
Roller track table						
203020, 203021, 203022, 203520, 203521, 203522						●
203010, 203011, 203012	●	●				●
203510, 203511, 203512			●	●		●
Use without table					●	●



- Uprights**
- Short or long version
 - With screw fitting to table legs
 - Set = 2 pcs.

Order no.	W x D x H (mm)
2062	1170 mm, above table 485 mm Weight 6 kg
2064	1770 mm, above table 1085 mm Weight 8 kg
2065	1170 mm, above table 485 mm Weight 4 kg
2066	1770 mm, above table 1085 mm Weight 13 kg

- Add-on frame for variable-height tables**
- Alternative for attaching accessories
 - Combinable with all the tables

Order no.	W x D x H (mm)
206411	For table width 1600 W x D x H (mm): 1215 x 810 x 1800 Weight 26 kg
206410	For table width 2000 W x D x H (mm): 1800 x 810 x 1800 Weight 29 kg



The uprights or mounting frame form the basis for all accessories fitted above the table. Please also note that suitably sized accessories are available for table widths 1600 and 2000. Your local dealer will be pleased to advise you about putting together the best solution for your own requirements.

Project examples

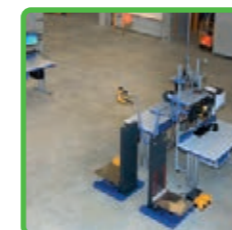

New system



Retrofit

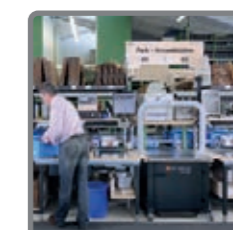
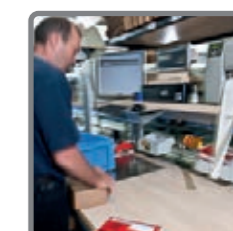
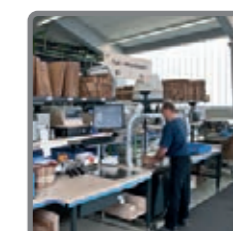

Assembly workplace



Accessories above the table SYSTEM 1200, SYSTEM 1600, SYSTEM 2000

Accessories for perforated back panels on Page 96

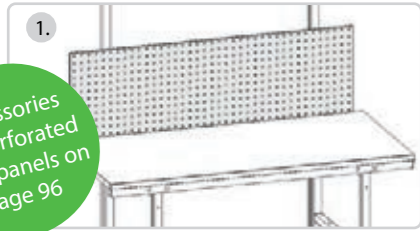

Perforated back panel® RasterPlan

- Perforated panel for hooking on tools

Order no.	W x D x H (mm)
707016 For table width 1600	W x H 1500 x 450 Weight 9 kg
707116 For table width 1600	1/3 slotted panel and 2/3 perforated panel W x H 1500 x 450 Weight 9 kg
707020 For table width 2000	W x H 2000 x 450 Weight 12 kg

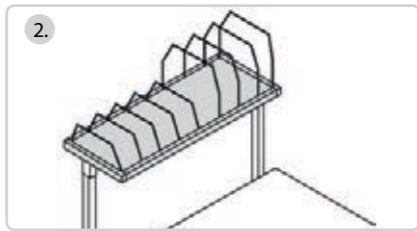

Add-on storage rack

- Dividers
- Flexible clamp assembly
- Max. surface load 50 kg

Order no.	W x D x H (mm)
1653 For table width 1600	1015 x 600 x 400 3 x small brackets 3 x large brackets Weight 20 kg
2053 For table width 2000	1600 x 600 x 400 5 x small brackets 4 x large brackets Weight 28 kg
1653D For table width 1600	Without dividers, etc. For installing retracting printer platform, Weight 17 kg
2053D For table width 2000	Without dividers, e.g. for installing retracting printer platform Weight 25 kg

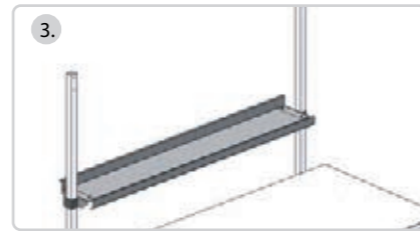

Document shelf

- Made of sheet steel
- Flexible clamp assembly
- Max. surface load 25 kg

Order no.	W x D x H (mm)
1650 For table width 1600	W x H 1045 x 230 Weight 5 kg
2050 For table width 2000	W x H 1630 x 230 Weight 7 kg

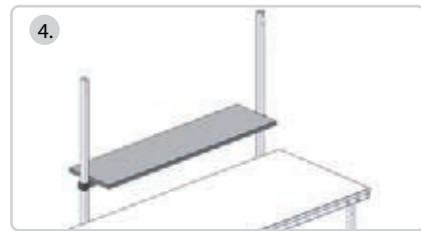

Storage shelf

- 30 mm melamine resin-coated wood
- Flexible clamp assembly
- Max. surface load 50 kg

Order no.	W x D x H (mm)
704740 For table width 1600	W x D 1046 x 400 Weight 6 kg
704750 For table width 2000	W x D 1600 x 400 Weight 15 kg

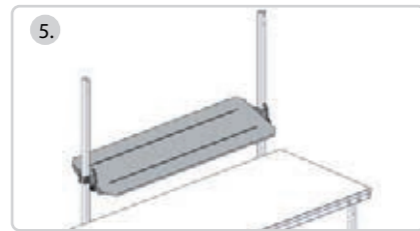

Inclined shelf

- Made of sheet steel
- Flexible clamp assembly
- Infinitely adjustable angle
- With raised edge
- Max. surface load 50 kg

Order no.	W x D x H (mm)
704700 For table width 1600	1045 x 450 x 60 Weight 10 kg
704800 For table width 2000	1630 x 450 x 60 Weight 20 kg



Workplace lighting

- For attachment to add-on storage rack (1653, 2053, 505300) or Bracket for attaching workplace lighting (207001, 207002)
- 207004 can also be mounted under the add-on storage rack 1653
- 207003: 1409 LUX, 4000 K, 3368 lm
- 207004: 903 LUX, 4000 K, 2158 lm
- 0,15 A, I/IP30
- plus 4m connecting cable with safety plug

Order no.	W x D x H (mm)
207004	661 x 51 x 54
207003	976 x 51 x 54 Weight 5 kg



Bracket for attaching workplace light

- For attachment to uprights
- For workplace light no. 207003 + 207004

Order no.	W x D x H (mm)
207002 For table width 1600 and 1200	1145 x 515 x 40 Weight 1 kg
207001 For table width 2000	1730 x 515 x 40 Weight 1 kg

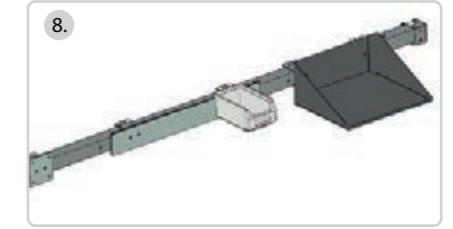

Multifunctional spar

- For attaching further accessories

Order no.	W x D x H (mm)
704711 For table width 1600	1055 x 40 x 40 Weight 2 kg
704710 For table width 2000	1640 x 40 x 40 Weight 4 kg
705081	Multipurpose shelf 315 x 240 x 130 Weight 3 kg
704714	Holder incl. 5 storage bins, size 7



Utensil holder XXL

- For mounting on multifunctional spar 704711 / 704710
- incl. dividers

Order no.	W x D x H (mm)
705116 For table width 1600	800 x 200 x 90 Weight 6 kg
705100 For table width 2000	1616 x 200 x 90 Weight 7 kg
122052	dividers 2 pieces



Adhesive tape holder

- for attaching to square tubing

Order no.	W x D x H (mm)
209205	90x227x78

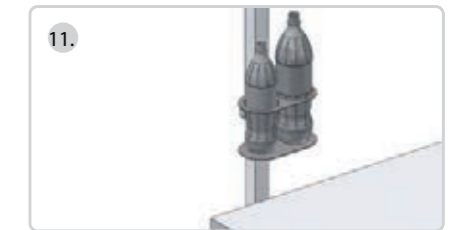

Bottle holder

- for one small bottle and one 1.5l bottle

Order no.	W x D x H (mm)
228200	207x176x129



All shelves are infinitely adjustable in height for adapting them to your needs.

Accessories on and underneath the table SYSTEM 1600, SYSTEM 2000

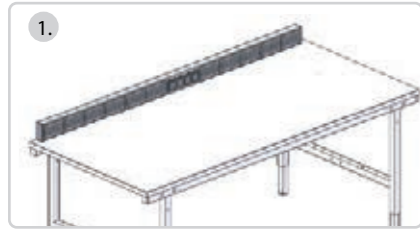

Backboard with power strip

- Power strip for use with sockets no. 2072
- Incl. plastic cover
- 4x socket strip

Order no.	W x D x H (mm)
208516 For table width 1600	1590 x 50 x 100 Weight 8 kg
208520 For table width 2000	1890 x 50 x 100 Weight 11 kg

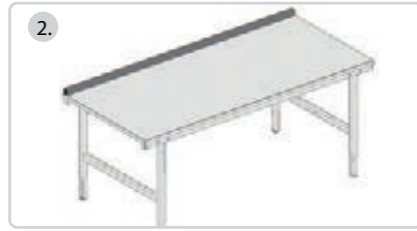

Backboard

- Square tubing 40 x 40 mm

Order no.	W x D x H (mm)
126000 For table width 1200	1200 x 40 x 40 Weight 4 kg
166000 For table width 1600	1600 x 40 x 40 Weight 4 kg
206000 For table width 2000	2000 x 40 x 40 Weight 5 kg

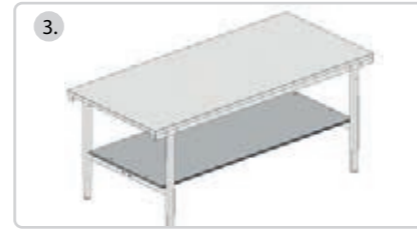

Bottom shelf

- Max. surface load 100 kg

Order no.	W x D x H (mm)
160900 For table width 1600	1135 x 650 x 19 Weight 16 kg
200900 For table width 2000	1720 x 770 x 19 Weight 25 kg

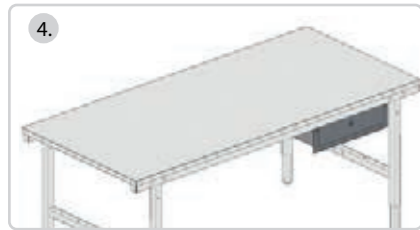

Steel drawer

- Lockable
- For use on right and/or left underneath table
- Plastic guide rail
- With drawer stops
- Load capacity 35 kg

Order no.	W x D x H (mm)
200600	520 x 500 x 150 Interior dimensions: 460 x 495 x 120 Weight 9 kg



Two drawers

- Separately lockable
- For use on right and/or left underneath table
- Telescopic guide rail
- Load capacity per drawer 20 kg

Order no.	W x D x H (mm)
200620	520 x 500 x 320 Interior dimensions: 460 x 495 x 120 Weight 16 kg



Cupboard unit

- With 1 drawer and 1 cupboard door
- Separately lockable
- Cupboard door can be hung on right or left

Order no.	W x D x H (mm)
2011	535 x 600 x 785 Interior dimensions: 490 x 570 x 430 Weight 45 kg



Drawer unit

- With 3 drawers
- Central locking mechanism
- Retraction 420 mm
- Max. load 25 kg per drawer

Order no.	W x D x H (mm)
2010	535 x 600 x 785 Interior dimensions: 430 x 550 x 180 Weight 45 kg



Steel container

- Mobile
- With 4 castors, 2 with brake function
- With plastic insert for waste disposal
- Max. load capacity 30 kg.

Order no.	W x D x H (mm)
200800	500 x 650 x 525 Weight 18 kg



Gap Cover

- Cover between the bars (for double workstation)

Order no.	W x D x H (mm)
163003	1051 x 40 x 70 Weight 2 kg
203003	1636 x 40 x 70 Weight 3 kg



Castor set

- For variable height packing tables
- Set of 4 castors, 2 with brake function
- ø 125 mm
- Height 162 mm

Order no.	W x D x H (mm)
2030-2 For table width 1200, table width 1600 and table width 2000	ø 125



Undertable cutter, mobile

- Dispensing height 580 mm
- Order no. 25507, suitable for order nos. 2011 and 2010
- 4 castors, of which 2 are lockable
- Max. roll weight 200 kg
- Max. roll ø 750 mm

Order no.	Roll width mm	W x D x H (mm)
25507	750	1000 x 880 x 740
25510	1000	1250
25512	1250	1500



Mobile roll dispenser

- 4 castors, of which 2 are lockable
- Max. roll weight 200 kg
- Max. roll ø 500 mm

Order no.	Roll width mm	W x D x H (mm)
23107	750	1000 x 880 x 740
23110	1000	1250
23112	1250	1500

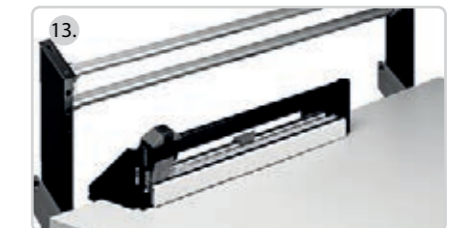

Add-on cutter

- Max. clamping range 70 mm
- Suitable for 203000 and 503000

Order no.	W x D x H (mm)
55107	Cutting width 750 mm
55110	Cutting width 1000 mm
55112	Cutting width 1250 mm



Spindle set, complete

- Spindle tube diameter 32 mm, for roll widths up to 1600 mm
- 1 pair of cones and clamp rings for adjusting roll and spindle
- Max. roll weight 100 kg

Order no.	W x D x H (mm)
23900	1850 x 32 ø Weight 4 kg
23910	1000 x 32 ø Weight 4 kg
23800	Horiz. bearing shell for roll spindle Weight 1 kg



Undertable storage rack, mobile

- One level, for approx. 160 folding cartons
- 4 castors, of which 2 are lockable
- Max. surface load 100 kg

Order no.	W x D x H (mm)
2042 Undertable storage rack, short, 1 level	1015 x 600 x 604 Weight 21 kg
2042-1 Undertable storage rack Short, 1 level, with telescopic handle	1015 x 600 x 690 Weight 23 kg



Undertable storage rack, mobile

- One level, for approx. 100 folding cartons
- 4 castors, of which 2 are lockable
- Max. surface load 100 kg

Order no.	W x D x H (mm)
2043 Undertable storage rack, long, 1 level	1600 x 600 x 604 Weight 27 kg
2043-1 Undertable stor- age rack, long, 1 level, with telescopic handle	1600 x 600 x 690 Weight 31 kg

Other cutters
from
page 90

More trans-
porting devices
from page 98
onwards

IT accessories SYSTEM 1200, SYSTEM 1600, SYSTEM 2000



Support column with screw clamp

- For attaching a screen folding arm and a keyboard tray
- Aluminium profile with clamp attachment

Order no.	W x D x H (mm)
509001 Clamping range 14-40 mm	51 x 51 x 445 Weight 1.5 kg
509002 Clamping range 5-65 mm	51 x 51 x 445 Weight 2 kg
509006 Clamping range 5-65 mm	51 x 51 x 45 Weight 2 kg



Profile rail for PC folding arms

- Upright attachment with 2 clamp sections
- With 3 fastening grooves
- Suitable for double workplaces
- Weight 2 kg

Order no.	W x D x H (mm)
509005	H: 750



Screen folding arms

- For flexible attachment of a screen
- VESA 75/100 quick-release attachment

Order no.	W x D x H (mm)
509203 Load capacity 5 kg	100 x 455 x 115 Weight 1.6 kg
509204 Load capacity 15 kg	100 x 455 x 200 Weight 2.1 kg
509207 Load capacity 8 kg	100 x 455 x 200 branch (456-704mm)
509209 Load capacity 10 kg	100x700x200 branch (700 mm)

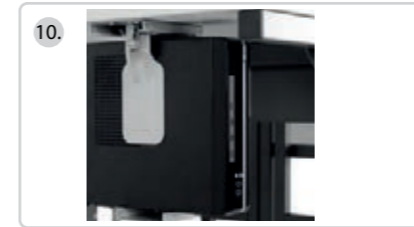

Mini PC holder

- For mounting underneath packing table
- Interior height 205-360 mm
- Interior width 50-100 mm
- Weight 2 kg

Order no.	W x D x H (mm)
228110	160 x 115 x 240-395



Keyboard and mouse platform

- With non-slip rubber surface for mounting on universal shelf 2082
- Weight 5 kg

Order no.	W x D x H (mm)
20812	760 x 210 x 20



Retracting printer platform

- For mounting on add-on storage rack no. 2053, 1653, 2053D, 1653D
- Weight 11 kg

Order no.	W x D x H (mm)
205350	375 x 658 x 100



Screen support carriage

- For flexible attachment of a screen on the supporting column or adapter
- Load capacity 12 kg
- Weight 1 kg

Order no.	W x D x H (mm)
509202	100 x 125 x 115



Tablet holder

- for attaching to screen folding arms
- for tablets from 7" to 10"
- clamping length 160 - 300 mm

Order no.	W x D x H (mm)
509214	

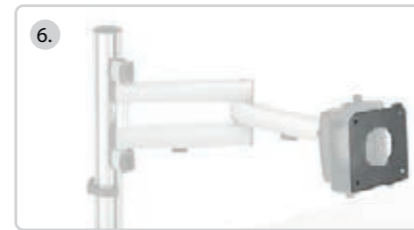

Thin client holder for screen folding arm

- for attachment between TFT folding arm and monitor
- suitable for Vesa 100 x 100 mm

Order no.	W x D x H (mm)
509211	Width 35 - 53



Keyboard and mouse platform with folding arm

- For flexible attachment to the supporting column or adapter
- shelf size: 640 x 172 mm
- Load capacity 10 kg
- Weight 1 kg

Order no.	W x D x H (mm)
509201	640 x 728 x 120



Upright adapter

- Adapter for folding arm and support carriage

Order no.	W x D x H (mm)
509003 For attaching 509201, 509202, 509203	47 x 67 x 120
509004 For attaching 509204, 509207, 509209	47 x 67 x 200



PC holder

- For mounting underneath packing table
- Incl. fastening screws and drilling template

Order no.	W x D x H (mm)
228100	100-242 x 150 x 320-545 Weight 3 kg
228101 Upright attachment for PC holder	130 x 240 x 120



Universal shelf

- For monitor, adhesive tape dispenser, etc.
- Clamp assembly on uprights
- Max. surface load 25 kg
- Weight 8 kg

Order no.	W x D x H (mm)
2082	440 x 520 x 90



Printer trolley, undertable version

- With storage tray for paper
- Mobile
- With 4 castors, 2 with brake function
- Load capacity 50 kg
- Weight 20 kg

Order no.	W x D x H (mm)
204251	500 x 600 x 240



4-socket outlet

- Clamp assembly on uprights
- Incl. 2.90 m connecting cable
- Weight 1 kg

Order no.	W x D x H (mm)
2074	61 x 45 x 304



Retracting keyboard and mouse platform

- Space-saving holder for mounting underneath storage shelf 704750
- Weight 2 kg

Order no.	W x D x H (mm)
208120	600 x 420 x 110



Retractable keyboard tray

- extendable mouse tray left or right
- minimum table top thickness 25 mm
- RAL 9006 white aluminium

Order no.	W x D x H (mm)
509318	300 x 565 x 100

Weighing accessories



Holder for scale display unit

- For flexible clamping to uprights

Order no.	W x D x H (mm)
2091	120 x 92 x 42 Weight 1 kg



Holder for scale display unit

- Attached at perforated sheet
- Mounting at Rhewa scale display unit

Order no.	W x D x H (mm)
509232	120 x 50 x 100 Weight 1 kg



Holder for scale display unit

- Attached at Screen-articulated arm
- Mounting at Rhewa scale display unit

Order no.	W x D x H (mm)
509206	120 x 50 x 100 Weight 1 kg

Ergonomic accessories and lifting aids SYSTEM 1600, SYSTEM 2000



Ergonomic workplace mat

- Protects the joints and spinal discs
- Bevelled edges for less risk of tripping
- Anti-slip surface

Order no.	W x D x H (mm)
600004 Dry version	1350 x 1000 x 16 Weight 19 kg
600005 Wet version	1350 x 1000 x 16 Weight 18 kg

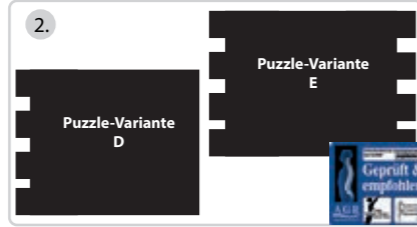

Ergonomic workplace mat

- Puzzle joint
- Protects the joints and spinal discs
- Bevelled edges for less risk of tripping
- Anti-slip surface

Order no.	W x D x H (mm)
600007 Puzzle variant D	1300 x 1000 x 16 Weight 30 kg
600009 Puzzle variant E	1240 x 1000 x 16 Weight 15 kg



ErgoPlus 3000 standing aid

- Incl. foot rest
- Infinite adjustment of the seat cushion
- Collapsible
- Weight 12 kg

Order no.	W x D x H (mm)
519192	670 x 500 x 1100



Saddle stool

- Ergonomic saddle seat
- Seat tilt adjustment
- Adjustment range 630-890 mm
- Weight 10 kg

Order no.	W x D x H (mm)
852086	478 x 445 x 660



Footrest

- With inclined tread surface

Order no.	W x D x H (mm)
5185	470 x 370 x 120



Footrest

- Variable height 110-320 mm
- Moveable plastic tread plate
- Adjustable angle: 0°-30°
- Weight 7 kg

Order no.	W x D x H (mm)
852038	520 x 375 x 140



Corner tables

Order no.	W x D x H (mm)
203100 Free-standing with 4 legs, max. load capacity 300 kg	920 x 920 x 690-960
203110 Attached, square with stand leg, max. surface load 50 kg	920 x 920 x 690-960
203120 Attached, trapezoid with stand leg, max. surface load 50 kg	920 x 700 x 690-960



Side table for carton scale

- Max. surface load 100 kg

Order no.	W x D x H (mm)
209000	600 x 600 x 770 Weight 17 kg
209034	600 x 600 x 605-875 Weight 19 kg



Packing and order picking trolley

- Height adjustment with gas pressure cylinder
- Max. load capacity 30 kg
- Weight 52 kg
- Max. load capacity of lifting system 30 kg

Order no.	W x D x H (mm)
209040	700 x 800 x 700 - 920



NEW

Mobile electric lift table

- height adjustment via electric motor
- with three working height memory positions
- mobile with 4 swivel castors
- incl. battery pack
- max. load capacity 60 kg
- max. load capacity of lifting system 80 kg
- speed of lifting system 38 mm/sec.

Order no.	W x D x H (mm)
209050	700 x 800 x 554-854



NEW

Stationary electric lift table

- height adjustment via electric motor
- with three working height memory positions
- max. load capacity 60 kg
- max. load capacity of lifting system 80 kg
- speed of lifting system 38 mm/sec.

Order no.	W x D x H (mm)
209051	700 x 800 x 540-840



Pneumatic lift table

- Allows effortless lifting and lowering of heavy cartons
- Requires 6 bar compressed air supply
- 250 mm lift height
- Max. load capacity 60 kg
- Weight 50 kg
- Speed of lifting system 160 mm/sec.

Order no.	W x D x H (mm)
209100	600 x 600 x 500-710



Pneumatic lift table, stainless steel platform

- Stainless steel platform WxD 450 x 600 mm
- Lift 500 mm
- Incl. foot switch
- Table prepared for bolting to floor
- Mounting materials not included
- Requires 6 bar compressed air supply
- Max. load capacity 60 kg
- Speed of lifting system 160 mm/sec.

Order no.	WxDxH(mm)
209101 Lift height 200-700 mm	450x735x1275
209102 Lift height 200-900 mm	450x735x1675



Pneumatic lift table, stainless steel platform

- Stainless steel platform WxD 450x600 mm
- Lift 500 mm resp. 700 mm
- Incl. foot switch
- Table with pedestal base
- Requires 6 bar compressed air supply
- Max. load capacity 60 kg
- Speed of lifting system 160 mm/sec.

Order no.	W x D x H (mm)
209103 Lift height 250 - 750 mm	450 x 845 x 1320
209104 Lift height 250 - 950 mm	450 x 840 x 1720

Other accessories SYSTEM 1600, SYSTEM 2000

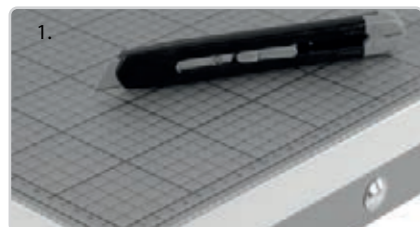

Cut-resistant overlay

- Transparent
- For traceless cuts
- Surface with slight anti-slip effect

Order no.	W x D x H (mm)
509400	900 x 600 x 3 Weight 2 kg



Cut-resistant overlay

- Protects parts of the worktop against damage from mechanical strain
- Bonded to table top with the supplied adhesive pads

Order no.	W x D x H (mm)
203095	1000 x 800 x 1 Stainless steel Weight 13 kg
203096	1000 x 800 x 2 Galvanised sheet steel Weight 12 kg



Reservoir made of PP cavity sheeting

- Mould and moisture-proof
- For hygienic applications, no fibre formation on the surface
- Shock-absorbing
- Set = 2 pcs.

Order no.	W x D x H (mm)
2056	600 x 500 x 600



Slice - Auto-Retractable Box Cutter

- Incl. one double-sided ceramic blade
- Automatically retractable blade
- 8-10 times sharper than a steel blade
- Easy blade change
- Injury-proof handling

Order no.	W x D x H (mm)
99090238	



Solo Lift Pro carry aid

- Practical, single-handed lifting aid for small, light boxes

Order no.	W x D x H (mm)
99090233	



Dual Lift Pro carry aid

- With 2 belt pouches
- Safe lifting of large and heavy cartons through effective load distribution

Order no.	W x D x H (mm)
99090234	



Display panel holder with magnetic attachment

- Display panel holder with 5 display panels, black
- Metal wall holder with magnetic back

Order no.	W x D x H (mm)
591401	



Display panel holder as table stand-up display

- Complete set made of powder-coated steel for table top use
- L-shaped, metal table stand-up display with 10 display panels, assorted colours

Order no.	W x D x H (mm)
557000	

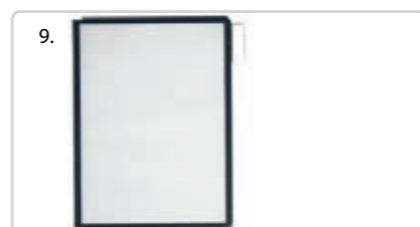

A4 display panel

- 5 display panels
- Polypropylene display panels with black all-round profile frame
- For DIN A4 info sheets

Order no.	W x D x H (mm)
560601	



Mobile hanging frame

- 360° swivel mounting

Order no.	W x D x H (mm)
2046	1050 x 700 x 2100-3500 Weight 50 kg
802045	Weight 2 kg Extension strut with bracket



Mobile cardboard storage rack

- Two levels
- With handle

Order no.	W x D x H (mm)
2042-2	1015 x 600 x 1260 Cardboard storage rack, short For approx. 200 folding cartons Weight 42 kg
2043-2	1600 x 600 x 1260 Cardboard storage rack, long, For approx. 320 folding cartons Weight 58 kg

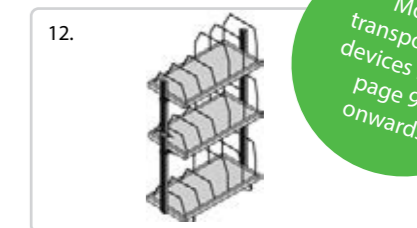

Mobile cardboard storage rack

- Three levels
- With handle

Order no.	W x D x H (mm)
2042-3	1015 x 600 x 1860 Cardboard storage rack, short For approx. 300 folding cartons Weight 64 kg
2043-3	1600 x 600 x 1860 Cardboard storage rack, long, For approx. 480 folding cartons Weight 88 kg

More transporting devices from page 94 onwards



Rubbish bin

- holding capacity 90l
- with handles for easy transportation

Order no.	W x D x H (mm)
99090241	520 x 490 x 610



Trolley for 90 litre rubbish bin

- carriage white varnished metal
- four swivel castors
- total height when using rubbish bin: 740 mm

Order no.	W x D x H (mm)
99090240	395 x 385 x 180

SYSTEMATIC



Add-on storage rack can be mounted level or inclined

HR mounting profile
For inclined mounting at 0° or 20°

Shelf can be hooked on at
+20°, 0°, -20°

Screen and keyboard holder
with double-joint arm

Thin client
holder

Horizontally adjustable
HR mounting profile



The HR mounting profiles are the real star of SYSTEM FLEX. Lateral grooves are used for the infinitely variable attachment of components such as perforated back panels, monitor swivel arms and other accessories. The front sides have a grid perforation of 39:39 mm for quickly hanging on shelves, retracting platforms, roll holders and other components without screws.

SYSTEM FLEX



Ergonomic Product

Certificate

The IGR Institute certifies that the test has been passed

Rocholz GmbH
Neugieserstraße 240-242
42553 Velbert

SYSTEM FLEX

The test carried out by the Institut für Gesundheit und Ergonomie e.V. (IGR e.V.) confirms the usability and ergonomics of the product. The tests are based on the specifications of the standards DIN 33 419 / EN ISO 15537. The examination investigated the degree of adaptation of the product to the physical characteristics of the test subjects.

IGR Institut für Gesundheit und Ergonomie

IGR e.V. – Vorstand
Nuremberg, 01 May 2016

Combine the possibilities

Ergonomics play a key role, but not at the expense of flexibility. The top section of the mounting profile can be mounted upright or inclined by 20 degrees. This significantly improves the grip position of the shelves and accessories. By detaching the mounting profiles from the table leg, the structures can additionally be moved horizontally to any position to accommodate conveyor system connections, for instance.



Special features at a glance:

- The HR profile tube combines the advantages of an aluminium profile and a sturdy steel construction to create a totally innovative and exceedingly flexible concept.
- The front sides of the HR mounting profiles have a grid perforation of 39:39 mm for quickly hanging on shelves, roll holders and other components without screws. This means that you can easily adapt the table to suit your processes, even when they change.
- The lateral grooves are used to attach components such as perforated back panels, monitor swivel arms and other accessories and flexibly adjust their height. New accessories can be easily added as required.
- The top section of the HR mounting profile can be mounted upright or inclined by 20 degrees. This significantly improves the grip position of the add-on parts! The grip area becomes more ergonomic for the workers. The carrier arms can also be mounted at an angle of -20°, 0° and +20°. This results in numerous combination possibilities.
- By detaching the mounting profiles from the table leg, the structures can also be infinitely moved horizontally on the frame to accommodate conveyor system connections, for instance.
- The first packing table that has been certified by the German interest group of back-training teachers as an ergonomic product.
- Daisy-chaining, integration and adaptation options offer countless possibilities from single workplaces up to complete packaging lines.

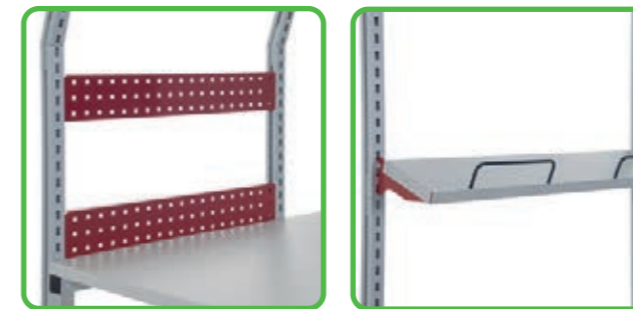

QUALITÄT
MADE
IN GERMANY



"Switching to the FLEX table system has resulted in a time optimisation of 20% per order in our delivery department. At the same time, our employees are motivated and relaxed when they finish work. We hadn't reckoned with that."

Jan H., logistics manager

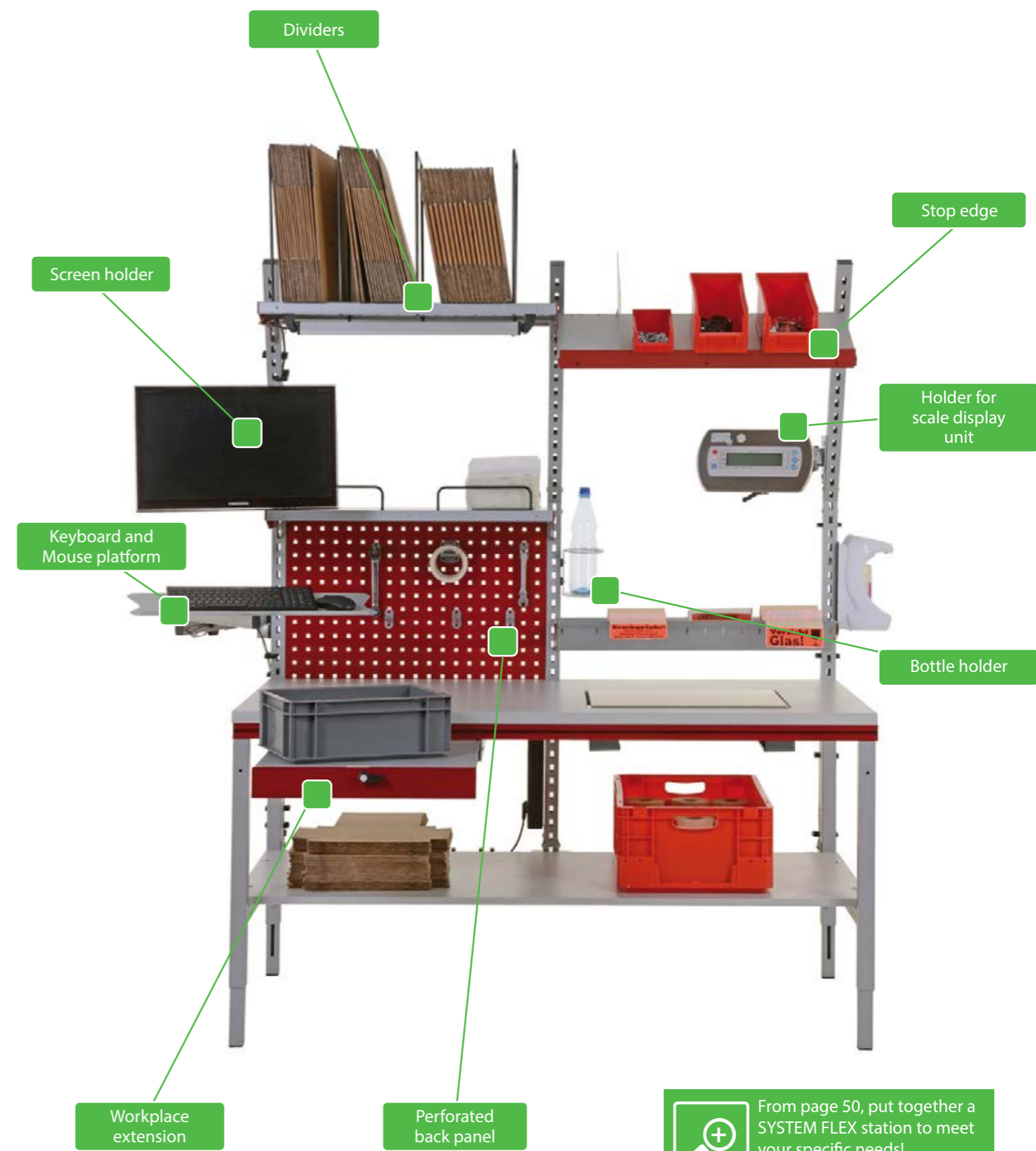

From page 50, put together a SYSTEM FLEX station to meet your specific needs!

Basic table SYSTEM FLEX



SYSTEM FLEX basic table manually

Tubular steel frame 40x40 mm, functional struts and rear cross members made of HR profile tube, infinitely variable height 690-960 mm with clamping screws, worktop 30 mm thick, melamine resin coating, light grey surface with 2 mm ABS edge, functional struts in accentuating colour, max. surface load 300 kg

Dimensions	Accentuating colour	Order no.
W x D x H: 1200 x 800 x 690-960 mm	Ruby red	73000000
W x D x H: 1200 x 800 x 690-960 mm	Gentian blue	73000001
W x D x H: 1600 x 800 x 690-960 mm	Ruby red	73000100
W x D x H: 1600 x 800 x 690-960 mm	Gentian blue	73000101
W x D x H: 2000 x 800 x 690-960 mm	Ruby red	73000200
W x D x H: 2000 x 800 x 690-960 mm	Gentian blue	73000202

SYSTEM FLEX basic table with electric height adjustment

Tubular steel frame 40x40 mm, functional struts and rear cross members made of HR profile tube, infinitely variable height 720-1120 mm with electric motor, worktop 30 mm thick, melamine resin coating, light grey surface with 2 mm ABS edge, functional struts in accentuating colour, max. surface load 300 kg, max. load capacity of lifting system 400 kg, speed of lifting system 12 mm/sec.

Dimensions	Accentuating colour	Order no.
W x D x H: 1200 x 800 x 720-1120 mm	Ruby red	73000600
W x D x H: 1200 x 800 x 720-1120 mm	Gentian blue	73000601
W x D x H: 1600 x 800 x 720-1120 mm	Ruby red	73000700
W x D x H: 1600 x 800 x 720-1120 mm	Gentian blue	73000701
W x D x H: 2000 x 800 x 720-1120 mm	Ruby red	73000800
W x D x H: 2000 x 800 x 720-1120 mm	Gentian blue	73000801

SYSTEM FLEX Table frame manually

Tubular steel frame 40x40 mm, functional struts and rear cross members made of HR profile tube, infinitely variable height 720-1120 mm with clamp screws, functional struts in accentuating colour

Dimensions	Accentuating colour	Order no.
W x D x H: 1200 x 800 x 690-960 mm	Ruby red	73100000
W x D x H: 1200 x 800 x 690-960 mm	Gentian blue	73100001
W x D x H: 1600 x 800 x 690-960 mm	Ruby red	73100900
W x D x H: 1600 x 800 x 690-960 mm	Gentian blue	73100901
W x D x H: 2000 x 800 x 690-960 mm	Ruby red	73100202
W x D x H: 2000 x 800 x 690-960 mm	Gentian blue	73100201

SYSTEM FLEX table frame electric with electric height adjustment

Tubular steel frame 40x40 mm, functional struts and rear cross members made of HR profile tube, infinitely variable height 690-1090 mm with electric motor, functional struts in accentuating colour, max. load capacity of lifting system 400 kg, speed of lifting system 12 mm/sec.

Dimensions	Accentuating colour	Order no.
W x D x H: 1200 x 800 x 690-1090 mm	Ruby red	73100600
W x D x H: 1200 x 800 x 690-1090 mm	Gentian blue	73100601
W x D x H: 1600 x 800 x 690-1090 mm	Ruby red	73100700
W x D x H: 1600 x 800 x 690-1090 mm	Gentian blue	73100701
W x D x H: 2000 x 800 x 690-1090 mm	Ruby red	73100800
W x D x H: 2000 x 800 x 690-1090 mm	Gentian blue	73100801

All electrically height-adjustable SYSTEM FLEX tables are equipped as standard with our control panel with fourfold memory storage

Basic table set SYSTEM FLEX Light

SYSTEM FLEX Light allows you to use the advantages of a high-end pro-version at the price of an entry-level system. Our new "light version" with standard electrical height adjustment succeeds in balancing high-performance and cost-effective and therefore sets new standards for packing tables. Modular SYSTEM FLEX accessories such as shelves, holders and other ergonomically adjustable add-ons can be mounted above the table where they guarantee flexible functionality and expand your efficiency expertly.



SYSTEM FLEX Light basic table set

The SYSTEM FLEX Light basic table with standard electrical height-adjustment includes three HR mounting profiles, onto which the extensive FLEX range of accessories (system width 800 mm) above the table can be attached. Furthermore, two perforated back panels are included which function as crush protection and can also be used to store e.g. the hook range. Max. load capacity of lifting system 120 kg, speed of lifting system 31 mm/sec.

Dimensions	Accentuating colour	Order no.
W x D x H: 1650 x 800 x 720-1220 mm	RAL 9006/3003	73805200

SYSTEM FLEX Light, drawer

- useable space 600 x 250 x 120 mm
- max. load capacity 10 kg
- colour RAL 9006

Dimensions	Colour	Order no.
W x D x H: 650 x 265 x 125 mm	RAL 9006	73805600

Worktops SYSTEM FLEX



SYSTEM FLEX table top

- 30 mm worktop
- standard table top melamine resin coating
- ESD table top: HPL surface
- Light grey surface with 2 mm ABS edge

Order no.	W x D x H (mm)
73200010 Standard	1200 x 800 x 30
73200300 ESD conductivity as per IEC 61340-5-1	1200 x 800 x 30
73200110 Standard	1600 x 800 x 30
73200400 ESD conductivity as per IEC 61340-5-1	1600 x 800 x 30
73200210 Standard	2000 x 800 x 30
73200500 ESD conductivity as per IEC 61340-5-1	2000 x 800 x 30

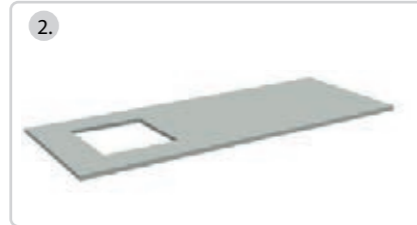

Table tops with scale cutout

- 30 mm worktop
- Melamine resin coating
- Light grey surface with 2 mm ABS edge
- Scale cutout: W x D: 516x416 mm
- Scale cutout left or right

Order no.	W x D x H (mm)
73200610 Standard	1200 x 800 x 30
73200700 Standard	1600 x 800 x 30
73200800 Standard	2000 x 800 x 30

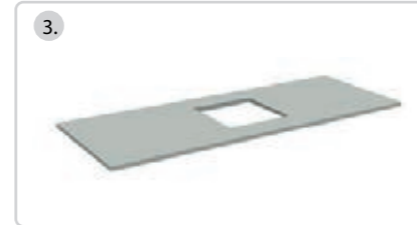

Table tops with scale cutout

- 30 mm worktop
- Melamine resin coating
- Light grey surface with 2 mm ABS edge
- Scale cutout: W x D: 516x416 mm
- Scale cutout in centre

Order no.	W x D x H (mm)
73201200 Standard	1200 x 800 x 30
73201300 Standard	1600 x 800 x 30
73201400 Standard	2000 x 800 x 30

Individual table cut-outs and mounting plates available on request!

For table tops with a scale cutout, a mounting plate must be ordered to integrate a scale. Order no. 73203700

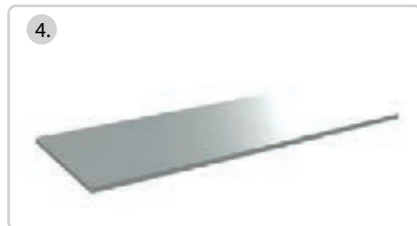

Table top, stainless steel cover

- 30 mm worktop

Order no.	W x D x H (mm)
73202100	1200 x 800 x 30
73202200	1600 x 800 x 30
73202300	2000 x 800 x 30



Multiplex table top

- 25 mm worktop, oiled

Order no.	W x D x H (mm)
73202400 Multiplex	1200 x 800 x 25
73202700 Finger-jointed	1200 x 800 x 25
73202500 Multiplex	1600 x 800 x 25
73202800 Finger-jointed	1600 x 800 x 25
73202600 Multiplex	2000 x 800 x 25
73202900 Finger-jointed	2000 x 800 x 25

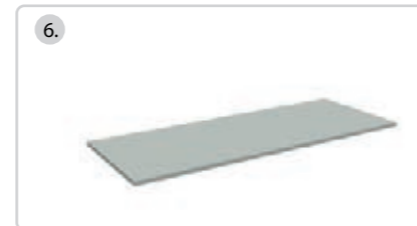

Bottom shelf

- Max. surface load 50 kg
- 73300400, 73300500, 73308400 only for tables with manual height adjustment
- 73300401, 73300501, 73300601 SYSTEM FLEX bottom shelf with electrical height adjustment

Order no.	W x D x H (mm)
73300401 ELT ground	978 x 600 x 19
73300400 Standard	1195 x 650 x 19
73300501 ELT ground	1378 x 600 x 19
73300500 Standard	1595 x 650 x 19
73300601 ELT ground	1778 x 600 x 19
73308400 Standard	1995 x 650 x 19

Roller track table SYSTEM FLEX



Locking plate

- for roller track tables with a roller track width of 600 mm + 75 division
- galvanised surface

Order no.	W x D x H (mm)
203544	600 x 125 x 62,5

SYSTEM FLEX, roller track table

Tubular steel frame 40x40 mm, functional struts and rear cross members made of HR profile tubing, infinitely variable height 690-960 mm via clamping screws, functional struts in RAL 9006 white aluminium

Dimensions	Order no.
W x D x H: 1200 x 680 x 690-960 mm	73400700

SYSTEM FLEX, roller track table

Tubular steel frame 40x40 mm, functional struts and rear cross members made of HR profile tubing, infinitely variable height 690-960 mm via clamping screws, functional struts in RAL 9006 white aluminium

Dimensions	Order no.
W x D x H: ca. 1730 x 680 x 690-960 mm	73400800

SYSTEM FLEX, roller track table

Tubular steel frame 40x40 mm, functional struts and rear cross members made of HR profile tubing, infinitely variable height 690-960 mm via clamping screws, functional struts in RAL 9006 white aluminium

Dimensions	Order no.
W x D x H: 2100 x 680 x 690-960 mm	73400900

Side Guide for roller track tables SYSTEM FLEX

Barrier for secure conveying of packets and packages on the roller track, Surface: RAL 9006 white aluminium

Dimensions	Order no.
W x D x H: 1195 x 40 x 40 mm	73408000
W x D x H: 1725 x 40 x 40 mm	73408100
W x D x H: 2100 x 40 x 40 mm	73408200

End stop for SYSTEM FLEX roller track table

height: 100 mm above the rolls, only in roll area

Dimensions	Order no.
W x D x H: 600 x 10 x 100 mm	73409100



Base frame

- for attaching the transfer plate
- infinitely variable height adjustment via clamping screws from 670 - 940 mm
- foot plate for floor mounting

Order no.	W x D x H (mm)
73600870	685 x 112 x 670 - 940

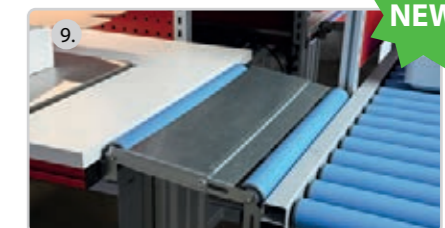

Transfer plate

- From tables to roller track tables with a width of 600 mm
- 265 mm min. distance between table and roller track table
- Telescope extension from 265-395 mm (130 mm extendable)

Order no.	W x D x H (mm)
73600230	620 x 265 - 395 x 104

Base frame SYSTEM FLEX



Base frame of add-ons elements

- mounting profiles with HR profile tubing
- with 2 functional grooves, 2 system perforation rows
- excl. assembly set for inclined installation 73308100

Order no.	W x D x H (mm)
73700000	837,5 x 750 x 1.974 800 mm wide
73700100	1.037,5 x 750 x 1.974 1.000 mm wide



Base frame for add-on elements

- mounting profiles with HR profile tubing
- with 2 functional grooves, 2 system perforation rows
- straight throughout

Order no.	W x D x H (mm)
73700200	837,5 x 750 x 2.046 800 mm wide
73700300	1.037,5 x 750 x 2.046 1.000 mm wide



Extension frame with add-on elements

- Anbauprofil aus HR-Profilrohr
- mit 2 Funktionsnuten, 2 Systemlochrillen
- 3.) straight, 2 parts
- 4.) continuous

Order no.	W x D x H (mm)
73700400	787,5 x 750 x 1.974 2-geteilt
73700500	987,5 x 750 x 1.974 2-geteilt
73700600	787,5 x 750 x 2.048 continuous
73700700	987,5 x 750 x 2.048 continuous

SYSTEM FLEX mounting profiles and shelves

The HR mounting profile combines the advantages of an aluminium profile and sturdy steel structure to create an innovative, flexible concept.



HR mounting profile, long

- With 2 functional grooves
- With 2 rows of system perforations
- Divided for upright or inclined mounting

Order no.	WxDxH(mm)
73308000 long version (1.)	1745 x 40 x 40
73312400 mounting profile long, continuous	1745 x 40 x 40
73308100 Assembly set for inclined installation (2.)	1745 x 40 x 40



HR mounting profile, short (basic)

- With 2 functional grooves
- With 2 rows of system perforations
- Height above table: 520 mm

Order no.	W x D x H (mm)
73309200 (3.)	1055 x 40 x 40



Retracting shelf with 100% extension

- For screwing into system grooves in mounting profiles
- Adjustable height in system perforations
- Ideal for label printers
- Max. surface load 40kg

Order no.	W x D x H (mm)
73303600 Ruby red	800 x 500 x 140
73303601 Gentian blue	800 x 500 x 140
73303702 Ruby red	1000 x 500 x 140
73303701 Gentian blue	1000 x 500 x 140

Shelves

For hooking into the system perforations in the mounting profiles, for inclining at -20°, 0° and +20°. Different widths and depths at two heights allow for countless combinations. The shelves are prepared for the use of shelf dividers and stop brackets. Shelf types A and type B are supplied with carrier arms. Max. surface load 25kg.

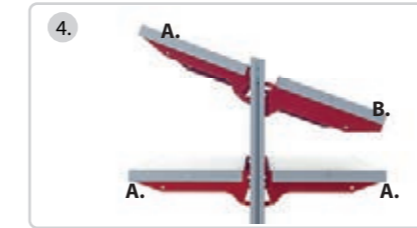

Shelves, type A

Order no.	W x D x H (mm)
73306900 Ruby red	800 x 200
73306901 Gentian blue	800 x 200
73307000 Ruby red	800 x 300
73307001 Gentian blue	800 x 300
73307100 Ruby red	800 x 400
73307101 Gentian blue	800 x 400
73307200 Ruby red	1000 x 200
73307201 Gentian blue	1000 x 200
73307300 Ruby red	1000 x 300
73307301 Gentian blue	1000 x 300
73307400 Ruby red	1000 x 400
73307401 Gentian blue	1000 x 400
73313000 Ruby red	1600 x 300
73313001 Gentian blue	1600 x 300

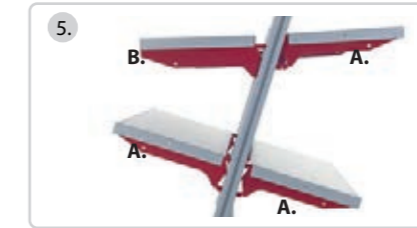

Shelves, type B

Order no.	W x D x H (mm)
73307500 Ruby red	800 x 300
73307501 Gentian blue	800 x 300
73307530 Ruby red	800 x 400
73307531 Gentian blue	800 x 400
73307600 Ruby red	1000 x 300
73307601 Gentian blue	1000 x 300
73307630 Ruby red	1000 x 400
73307631 Gentian blue	1000 x 400



Lifting protection

- SYSTEM FLEX, functions as protection against the carrier arms being lifted or levered up
- 1 sales unit: 10 pieces
- red plastic

Order no.	W x D x H (mm)
73314000	

Please note for two-sided shelving:

For trays which are at right angles to the spar, please order two tray types A, otherwise type A and type B must be combined as shown.

SYSTEM FLEX scales and weighing accessories



Digital table scale 60 kg

- Evaluation unit made of ABS plastic
- 2 m measuring cable with plug connector
- 230 V mains connection via external power adapter, 1,8 m cable
- Powder-coated, stainless steel weighing platform, W x D: 500x400 mm, for max. weight 60 kg, 20 g scale divisions, 1 strain gauge load cell made of anodised aluminium alloy, IP 66

Order no.	W x D x H (mm)
897052	500 x 400 x 82 Weighing area



Digital table scale, 60 kg, with calibration function, PC connection

- Stainless steel evaluation unit, protection class IP 67, 25 mm LCD display for gross, net or tare weight, tare correction, 10 customisable printouts, 1 RS232 serial port
- Powder-coated, stainless steel weighing platform, WxD: 500x400 mm, for max. weight 60 kg, 20 g scale divisions, 1 strain gauge load cell of anodised aluminium alloy, IP 66

Order no.	W x D x H (mm)
897062	500 x 400 x 82 Weighing area



Holder for scale display unit

- For flexible attachment of a scale display unit to the mounting profile with the supplied adapter
- Data cable must have a min. length of 2000 mm.
- Load capacity 15 kg

Order no.	W x D x H (mm)
73310700	117 x 325 x 135

Further weighing accessories are also available on page 39 in the catalog.

ProtecTable

ProtecTable is our SYSTEM FLEX add-on for integrating an automatic air cushion machine into your logistics workplace. The electric lift elevates the machine to its work position next to the storage silo and lowers it back to work table height for easy roll material changes. The storage silo is equipped with a storage net and mounting brackets ready for mounting to SYSTEM FLEX shelves, and collects the finished air cushions. The air cushions are stored in the silo for easy access through an opening in the net, allowing for direct processing at the workplace. The lift is operated via a hand switch and the cables are organised and protected at the side of the table by an energy chain. In combination with your air cushion machine, this system makes for simple and safe packaging processes. The optionally available installation panel with a 4-socket outlet can be installed between the packing table's Rocholz mounting profiles and can also hold the air cushion machine's control unit, if desired.

- efficient and ergonomic air cushion machine integration with storage silo
- max. load capacity: 30 kg, suitable for all standard air cushion machines
- lift-adjusting range approx. 1025 - 2325mm (1300mm stroke)
- dimensions platform
WxDxH: 330 x 402 x 221mm
- dimensions net and brackets for silo
WxDxH: 758 x 671 x 759mm

(mountable to 800mm wide shelves with a total depth of 600mm)



1 SYSTEM FLEX ProtecTable Air – lift

- electric lift for air cushion machine
- max. load capacity while using the platform (73316402): 30 kg
- adjusting range approx. 1025 - 2325 mm (1300mm stroke)
- incl. control unit and 220V power supply cable 2.3 m

Order no.	W x D x H (mm)
73316401	

2 SYSTEM FLEX ProtecTable Air – platform

- platform for air cushion machine incl. energy chain
- platform (WxDxH: 330 x 402 x 221mm) for e.g. air cushion machine
- incl. energy chain for guiding the cables and assembly set for lift and platform

Order no.	W x D x H (mm)
73316402	330 x 402 x 221

3 SYSTEM FLEX ProtecTable Air – silo

- storage net with mounting brackets for e.g. air cushions
- for assembly 800 mm wide SYSTEM FLEX shelves need to be in place and have a total depth of 600mm
- net colour: grey
- size WxDxH: 758 x 671 x 759mm

Order no.	W x D x H (mm)
73316201	758 x 671 x 759

DocumenTable

DocumenTable enables you to take photos for documentation right at your logistics table in your dispatch or incoming goods department. The first step is to scan the delivery note number with the integrated scanner; this activates the system. As soon as the packet (or one layer in the packet) is readily packed, you can trigger the camera by operating the foot-activated switch. The images are automatically named with the delivery note number and a date and time stamp (exact to the second); this assigns them clearly and uniquely. The generated data is saved to the integrated storage (standard: 25 GB) and can be retrieved over the corresponding network. An integrated and clearly visible LED strip shows the system status at any given time. Other distinct indicators for scanning, such as order number, packet number or customer number, can also be used as identifiers for images. The corresponding shelf for SYSTEM FLEX is fully equipped, readily installed and merely needs to be connected to your power supply and IT-network. Depending on the application situation, the system can be operated over a manual button or a (wireless) scanner instead of over the foot-switch.

- Entire documentation of images without broad IT-knowledge
- Distinct classification of stored data
- Transmission via LAN into your own server structure, connection to your own ERP system possible
- All-on-one solution without follow-up costs



Order no.	article description
73801201 gentian blue	DocumenTable camera left, W x D: 1000 x 400 mm
73801101 gentian blue	DocumenTable camera left, W x D: 800 x 400 mm
73800200 ruby red	DocumenTable camera left, W x D: 1000 x 400 mm
73800100 ruby red	DocumenTable camera left, W x D: 800 x 400 mm
73800401 gentian blue	DocumenTable camera right, W x D: 1000 x 400 mm
73800301 gentian blue	DocumenTable camera right, W x D: 800 x 400 mm
73800400 ruby red	DocumenTable camera right, W x D: 1000 x 400 mm
73800300 ruby red	DocumenTable camera right, W x D: 800 x 400 mm
73800000	DocumenTable Box, W x D x H: 300 x 250 x 76 mm

Accessories above the table



Cover rail

- for mounting between HR mounting profiles when using a combination of front and rear shelves, level installation

Order no.	W x D x H (mm)
73312000 for mounting width 800 mm	736 x 73 x 30
73312100 for mounting width 1000 mm	936 x 73 x 30



Partition

- for inserting into shelf perforations
- perforation pattern 50 mm

Order no.	W x D x H (mm)
73314700 300 mm deep shelves	300 x 180



Drawer with extension

- horizontally adjustable
- for mounting underneath shelves 400mm or 2x200mm
- load capacity 15 kg

Order no.	W x D x H (mm)
73600040 800 mm wide shelves	useable space 398 x 348
73600015 1.000 mm wide shelves	useable space 398 x 348



Stop bracket

- for inserting into the shelf perforation rows

Order no.	W x D x H (mm)
73301900	250



Shelf dividers

- for inserting into the shelf perforations
- open shelf divider
- sales unit = 4 pcs

Order no.	W x D x H (mm)
73308800	300 x 400



Stop edge

- for screwing onto the front of a shelf
- continuous edge with full shelf depth

Order no.	W x D x H (mm)
73302000 ruby red	800
73302001 gentian blue	800
73309400 ruby red	1000
73309401 gentian blue	1000
73314100 ruby red	1600
73314101 gentian blue	1600



complete spindle

- with cones and clamp rings
- two mounting widths
- incl. bearing shells for attachment between the mounting profiles

Order no.	WxDxH(mm)
73315010	800 mm
73315110	1000 mm

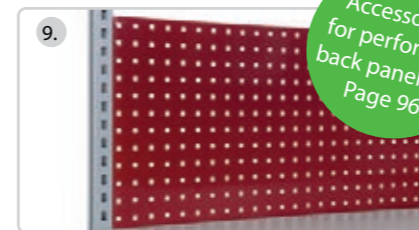

Accessories for perforated back panels on Page 96

Perforated back panel

- for screwing into system grooves in HR mounting profiles
- infinitely variable height, fits flush at the front and back (in the depth) with the HR mounting profiles

Order no.	W x D x H (mm)
73305500 ruby red	800 x 30 x 100
73305501 gentian blue	800 x 30 x 100
73302200 ruby red	800 x 30 x 200
73302201 gentian blue	800 x 30 x 200
73303400 ruby red	800 x 30 x 500
73303401 gentian blue	800 x 30 x 500
73305900 ruby red	1000 x 30 x 100
73305901 gentian blue	1000 x 30 x 100
73302300 ruby red	1000 x 30 x 200
73302301 gentian blue	1000 x 30 x 200
73306002 ruby red	1000 x 30 x 500
73306001 gentian blue	1000 x 30 x 500



Utensilo complete

- for hooking into system perforations
- incl. inclinable at 0° and 20°
- for storing roles of tape etc.
- plus four shelf dividers

Order no.	W x D x H (mm)
73312500 ruby red	800 x 200
73312501 gentian blue	800 x 200
73312600 ruby red	1000 x 200
73312601 gentian blue	1000 x 200
122052	Prisma Plus, dividers, 1 set = 2 pcs.



NEW

Holder for hand dispenser

- for attaching to square tubing or SYSTEM FLEX multifunctional spar

Order no.	W x D x H (mm)
73308200	110 x 38 x 78
73316800 MFS	105 x 183 x 78



Multifunctional rail

- for screwing between the HR mounting profiles
- max. load capacity 25 kg
- enables mounting various accessories
- RAL: 9006

Order no.	W x D x H (mm)
73303301	800
73303300	1000

SYSTEM FLEX lamps and lighting accessories



Workplace lighting LED with dimming function

- sturdy aluminium casing plus power supply
- can be adjusted to individual lighting needs

Order no.	W x D x H (mm)
73315610	976 x 51 x 54



Workplace lighting LED with dimming function

- sturdy aluminium casing plus power supply
- can be adjusted to individual lighting needs
- 903 LUX, 4000 K, 2158 lm

Order no.	W x D x H (mm)
73315710	661 x 51 x 54

Accessories at and underneath the table

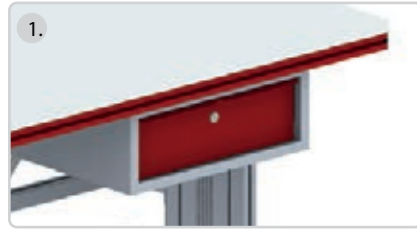

- Single drawer, lockable**
- front height: 150 mm
 - incl. assembly set
 - lockable
 - load capacity 35 kg

Order no.	W x D x H (mm)
73314500 ruby red	527 x 510 x 200 useable space: 450 x 445 x 120
73314501 gentian blue	527 x 510 x 200 useable space: 450 x 445 x 120



- Supplement drawer**
- front height: 150 mm
 - lockable, incl. assembly set
 - load capacity 35 kg per drawer

Order no.	W x D x H (mm)
73314600 ruby red	527 x 510 x 200 useable space: 450 x 445 x 120
73314601 gentian blue	527 x 510 x 200 useable space: 450 x 445 x 120



- Workplace extension**
- extensionlength 500 mm
 - usable area 500 x 450 mm
 - load capacity 50 kg

Order no.	W x D x H (mm)
73312300 ruby red	547 x 715 x 118
73312301 gentian blue	547 x 715 x 118



- Add-on cutter**
- cutting width 750 mm
 - for hooking on to HR mounting profile

Order no.	W x D x H (mm)
73303900	1000 x 50 x 150



- Roll holder**
- for screw attachment to HR mounting profile
 - max. roll weight 25 kg
 - max. roll width 750 mm
 - max. roll diameter 800 mm

Order no.	W x D x H (mm)
73304000	1000 x 450



- Spindle set**
- comprising of: 1 pair of cones, 4 clamp rings, 1 spindle, 2 cups
 - spindle tube diameter 32 mm
 - max. roll weight 100 kg

Order no.	W x D x H (mm)
73313100 for table width 1200	
73313200 for table width 1600	
73313300 for table width 2000	

Other cutters from page 90

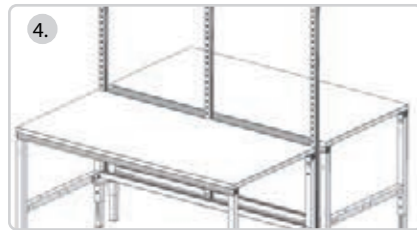

- Cover rail for double workspaces**
- for installation between the HR mounting profiles

Order no.	W x D x H (mm)
73600050	800 x 40
73312900	1000 x 40



- Extentable pole unit**
- infinitely extendable to 500 mm under the table
 - for attaching to functional struts

Order no.	W x D x H (mm)
73315500	515 x 715 x 133



- Dividers for cartons**
- for attaching to front functional strut and rear cross member

Order no.	W x D x H (mm)
73600504	463 x 753



- Bottle holder**
- for one small bottle and one 1.5l bottle
 - for flexible attachment in the system groove of the HR mounting profile

Order no.	W x D x H (mm)
73308500	210 x 125 x 130



- Under-table retracting shelf**
- suitable for e.g. printers
 - load-bearing capacity of max. 50 kg

Order no.	W x D x H (mm)
73315900	460 x 755 x 563



- Bin liner holder**
- suitable for standard bin liners

Order no.	W x D x H (mm)
73315903	329 x 319 x 52



- Retractable keyboard tray**
- extendable mouse tray left or right
 - minimum table top thickness 25 mm
 - RAL 9006 white aluminium

Order no.	W x D x H (mm)
509318	300 x 565 x 100

NEW

SYSTEM FLEX IT accessories



Thin client holder

- For screwing into the system grooves in the HR mounting profile
- Infinitely variable height adjustment

Order no.	W x D x H (mm)
73308300	300 x 70-120



Screen folding arms

- For flexible attachment of a screen
- VESA 75/100 quick-release attachment

Order no.	W x D x H (mm)
509203 Load capacity 5 kg	100 x 455 x 115
509204 Load capacity 15 kg	100 x 455 x 200
509207 Load capacity 8 kg	100 x 455 x 200 branch (456-704mm)
509209 Load capacity 10 kg	100 x 700 x 200 branch (700 mm)



Thin client holder for screen folding arm

- for attachment between TFT folding arm and monitor
- suitable for Vesa 100 x 100 mm

Order no.	W x D x H (mm)
509211	Width 35 - 53



Mini PC holder

- For mounting underneath the table, adjustable:
interior height 205-360 mm,
interior width 50-100 mm
- Incl. fastening screws and drilling template

Order no.	W x D x H (mm)
228110	160 x 115 x 240-395

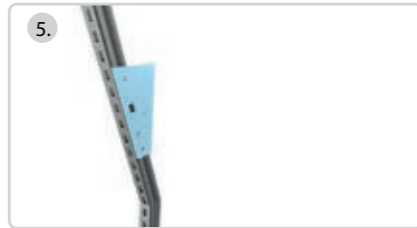

Adapter for Screen folding arms 509204 and 509203

- For attaching screen folding arms to inclined HR mounting profiles
- For positioning as required in the system grooves

Order no.	W x D x H (mm)
73313600	



Platform with folding arm

- For flexible attachment to the HR mounting profile
- Shelf area 404 x 288 mm
- Load capacity 10 kg

Order no.	W x D x H (mm)
509213	404 x 589 x 120



PC holder

- For mounting underneath the table, adjustable:
interior height 307-531 mm,
interior width 78-220 mm
- Incl. fastening screws and drilling template
- Weight 3 kg

Order no.	W x D x H (mm)
228100	100-242 x 150 x 320-545
73316700 Adapter for PC holder	RAL9006, for mounting on the feet of the SYSTEM FLEX tables electrically



Tablet holder

- for attaching to screen folding arms
- for tablets from 7" to 10"
- clamping length 160 - 300 mm

Order no.	W x D x H (mm)
509214	



Shelves with retracting keyboard tray (D: 300 mm)

- Incl. carrier arms
- Shelf and keyboard drawer with retracting mouse tray
- Horizontal sliding adjustment

Order no.	W x D x H (mm)
73316500 Ruby red	800 x 300
73316501 Gentian blue	800 x 300
73316600 Ruby red	1000 x 300
73316601 Gentian blue	1000 x 300



Keyboard and mouse platform with folding arm

- For flexible attachment to the supporting column or adapter
- shelf size: 640 x 172 mm
- Load capacity 10 kg
- Weight 1 kg

Order no.	W x D x H (mm)
509201	640 x 728 x 120



Holder for pens, cable ties, etc.

- Incl. bracket for attaching to HR mounting profiles

Order no.	W x D x H (mm)
73600086	87 x 195 x 128
73600253	87 x 195 x 280



Installation panel

- for attachment between the mounting profiles
- 4-socket outlet WITHOUT power/ connection cable

Order no.	W x D x H (mm)
73317100 ruby red	800 x 30 x 80
73317101 gentian blue	800 x 30 x 80
73317200 ruby red	1.000 x 30 x 80
73317201 gentian blue	1.000 x 30 x 80



Cable clips

- For cable management on HR profile uprights
- Set = 10 pcs.

Order no.	W x D x H (mm)
73312200	69 x 35 x 12



4-socket outlet

- For attachment to the HR mounting profile using the supplied assembly set
- Power connection 230 V, 16 A

Order no.	W x D x H (mm)
73311600 Black, without power cord	61 x 45 x 304
73310200 Power cord 3 m	
73311400 Connecting cable 2.5 m	



Cable tray

- For attachment to the table functional struts

Order no.	W x D x H (mm)
73600088	600 x 125 x 116
73600026	800 x 125 x 116
73311600 Black socket, without power cord	61 x 45 x 304
73310200 Power cord 3 m	
73311400 Connecting cable 2.5 m	

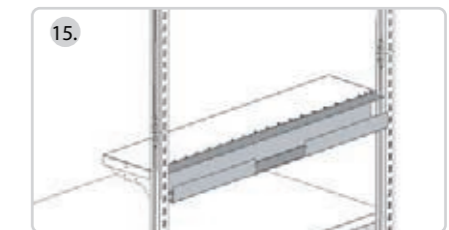

Cable duct

- For attachment to shelves
- Can also be used as a cover rail on double-sided shelves

Order no.	W x D x H (mm)
73312700	730 x 72 x 93
73312800	930 x 72 x 93
73311600 Black socket, without power cord	61 x 45 x 304
73310200 Power cord 3 m	
73311400 Connecting cable 2.5 m	

Ergonomic accessories and lifting aids SYSTEM FLEX



Ergonomic workplace mat

- Protects the joints and spinal discs
- Bevelled edges for less risk of tripping
- Anti-slip surface

Order no.	W x D x H (mm)
600004 Dry version	1350 x 1000 x 16 Weight 19 kg
600005 Wet version	1350 x 1000 x 16 Weight 18 kg

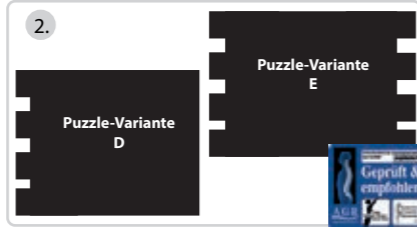

Ergonomic workplace mat

- Puzzle joint
- Protects the joints and spinal discs
- Bevelled edges for less risk of tripping
- Anti-slip surface

Order no.	W x D x H (mm)
600007 Puzzle variant D	1300 x 1000 x 16 Weight 30 kg
600009 Puzzle variant E	1240 x 1000 x 16 Weight 15 kg



ErgoPlus 3000 standing aid

- Incl. foot rest
- Infinite adjustment of the seat cushion
- Collapsible
- Weight 12 kg

Order no.	W x D x H (mm)
519192	670 x 500 x 1100



Saddle stool

- Ergonomic saddle seat
- Seat tilt adjustment
- Adjustment range 630-890 mm
- Weight 10 kg

Order no.	W x D x H (mm)
852086	478 x 445 x 660



Footrest

- With inclined tread surface

Order no.	W x D x H (mm)
5185	470 x 370 x 120



Footrest

- Variable height 110-320 mm
- Moveable plastic tread plate
- Adjustable angle: 0°-30°
- Weight 7 kg

Order no.	W x D x H (mm)
852038	520 x 375 x 140



Packing and order picking trolley

- Height adjustment with gas pressure cylinder
- Max. load capacity 30 kg
- Weight 52 kg
- Max. load capacity of lifting system 30 kg

Order no.	W x D x H (mm)
209040	700 x 800 x 700-920



Pneumatic lift table

- Allows effortless lifting and lowering of heavy cartons
- Requires 6 bar compressed air supply
- 250 mm lift height
- Max. load capacity 60 kg
- Weight 50 kg
- Speed of lifting system 160 mm/sec.

Order no.	W x D x H (mm)
209100	600 x 600 x 500-710



Table trolley

- top shelf incl. 2 stop edges, useable area: 500 x 405 mm, height 800 mm, max. load capacity 60 kg
- bottom shelf, useable area: 400 x 320 mm, height-adjustable: 245 - 745 mm, max. load capacity 15 kg
- 4 swivel castors, 2 lockable

Order no.	W x D x H (mm)
73313700	500 x 405 x 800



NEW

Mobile electric lift table

- height adjustment via electric motor
- with three working height memory positions
- mobile with 4 swivel castors
- incl. battery pack
- max. load capacity 60 kg
- max. load capacity of lifting system 80 kg
- speed of lifting system 38 mm/sec.

Order no.	W x D x H (mm)
209050	700 x 800 x 554-854



NEW

Stationary electric lift table

- height adjustment via electric motor
- with three working height memory positions
- max. load capacity 60 kg
- max. load capacity of lifting system 80 kg
- speed of lifting system 38 mm/sec.

Order no.	W x D x H (mm)
209051	700 x 800 x 540-840



Pneumatic lift table, stainless steel platform

- Stainless steel platform WxD 450 x 600 mm
- Lift 500 mm
- Incl. foot switch
- Table prepared for bolting to floor
- Mounting materials not included
- Requires 6 bar compressed air supply
- Max. load capacity 60 kg
- Speed of lifting system 160 mm/sec.

Order no.	W x D x H (mm)
209101 Lift height 200-700 mm	450 x 735 x 1275
209102 Lift height 200-900 mm	450 x 735 x 1675



Pneumatic lift table, stainless steel platform

- Stainless steel platform WxD 450x600 mm
- Lift 500 mm resp. 700 mm
- Incl. foot switch
- Table with pedestal base
- Requires 6 bar compressed air supply
- Max. load capacity 60 kg
- Speed of lifting system 160 mm/sec.

Order no.	W x D x H (mm)
209103 Lift height 250-750 mm	450 x 845 x 1320
209104 Lift height 250-950 mm	450 x 840 x 1720

Other accessories SYSTEM FLEX

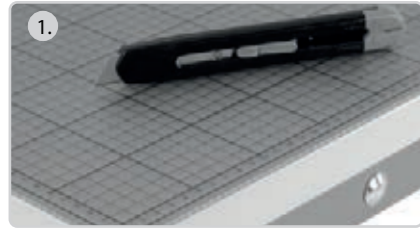

Cut-resistant overlay

- Transparent
- For traceless cuts
- Surface with slight anti-slip effect

Order no.	W x D x H (mm)
509400	900 x 600 x 3 Weight 2 kg



Cut-resistant overlay

- Protects parts of the worktop against damage from mechanical strain
- Bonded to worktop with the supplied adhesive pads

Order no.	W x D x H (mm)
203095 Stainless steel	1000 x 800 x 1 Weight 13 kg
203096 Galvanised sheet steel	1000 x 800 x 2 Weight 12 kg



Reservoir made of PP cavity sheeting

- Mould and moisture-proof
- For hygienic applications, no fibre formation on the surface
- Shock-absorbing
- Set = 2 pcs.

Order no.	W x D x H (mm)
2056	600 x 500 x 600



Slice - Auto-Retractable Box Cutter

- Incl. one double-sided ceramic blade
- Automatically retractable blade
- 8-10 times sharper than a steel blade
- Easy blade change

Order no.	W x D x H (mm)
99090238	



Solo Lift Pro carry aid

- Practical, single-handed lifting aid for small, light boxes

Order no.	W x D x H (mm)
99090233	



Dual Lift Pro carry aid

- With 2 belt pouches
- Safe lifting of large and heavy cartons through effective load distribution

Order no.	W x D x H (mm)
99090234	



Display panel holder with magnetic attachment

- Display panel holder with 5 display panels, black
- Metal wall holder with magnetic back

Order no.	W x D x H (mm)
591401	



Display panel holder as table stand-up display

- Complete set made of powder-coated steel for table top use
- L-shaped, metal table stand-up display with 10 display panels, assorted colours

Order no.	W x D x H (mm)
557000	



A4 display panel

- 5 display panels
- Polypropylene display panels with black all-round profile frame
- For DIN A4 info sheets

Order no.	W x D x H (mm)
560601	



Mobile hanging frame

- 360° swivel mounting

Order no.	W x D x H (mm)
2046	1050 x 700 x 2100-3500 Weight 50 kg
802045 Extension strut with bracket	Weight 2 kg



Mobile cardboard storage rack

- Two levels
- With handle

Order no.	W x D x H (mm)
2042-2 Cardboard storage rack, short For approx. 200 folding cartons	1015 x 600 x 1260 Weight 42 kg
2043-2 Cardboard storage rack, long, For approx. 320 folding cartons	1600 x 600 x 1260 Weight 58 kg

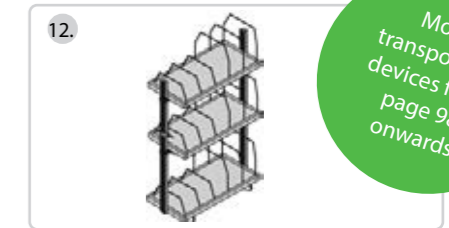

Mobile cardboard storage rack

- Three levels
- With handle

Order no.	W x D x H (mm)
2042-3 Cardboard storage rack, short For approx. 300 folding cartons	1015 x 600 x 1860 Weight 64 kg
2043-3 Cardboard storage rack, long, For approx. 480 folding cartons	1600 x 600 x 1860 Weight 88 kg

More transporting devices from page 98 onwards



Rubbish bin

- holding capacity 90l
- with handles for easy transportation

Order no.	W x D x H (mm)
99090241	520 x 490 x 610



Trolley for 90 litre rubbish bin

- carriage white varnished metal
- four swivel castors
- total height when using rubbish bin: 740 mm

Order no.	W x D x H (mm)
99090240	395 x 385 x 180

Assistance and documentation systems

AssisTable

AssisTable is a digital work catalogue that assists users in picking and packing processes. Work steps are impacted by different factors; therefore, there are certain specifications as to how the item should be packed or processed and which documents should be added, depending on the supplier, destination country and/or certain item properties. The individual steps are shown in short form and with images. At the same time an integrated quality report records the factually performed activities and quantities. In this way, data is generated that can be used, for instance, for a billing model or for forward-looking capacity planning. The user-friendly interface ensures that the system can be used and work catalogues can be generated or updated after a short period of familiarisation and without broad IT-knowledge. Depending on requirements and intended purpose, the system can naturally be adapted individually.

- Economical added-value service
- Self-determined work in spite of product individualisation and large variety
- Server-based system that can be operated location-independently
- Automatic generation of economic indicators via digitalisation

InspectTable

InspectTable allows you to identify deviations and errors at an early stage – before the goods arrive with the customer. The image-based system compares the given situation with the pre-fed target situation and can analyse individual articles and their layers or positions as well as the entire picture. Machine Learning not only enables distinguishing between correct and false, but, depending on the intended application, also viewing percentage detection data and feeding individual groups into the system. The system is characterised by the ability to adapt flexibly to different working conditions and requirements; furthermore, there is no need for broad IT-knowledge as the set-up is so simple.

- Zero-fault-production due to optical monitoring
- Flexible system that only needs to be pre-trained once for a particular application
- Self-learning system that develops continuously with each task
- Optional maintenance service

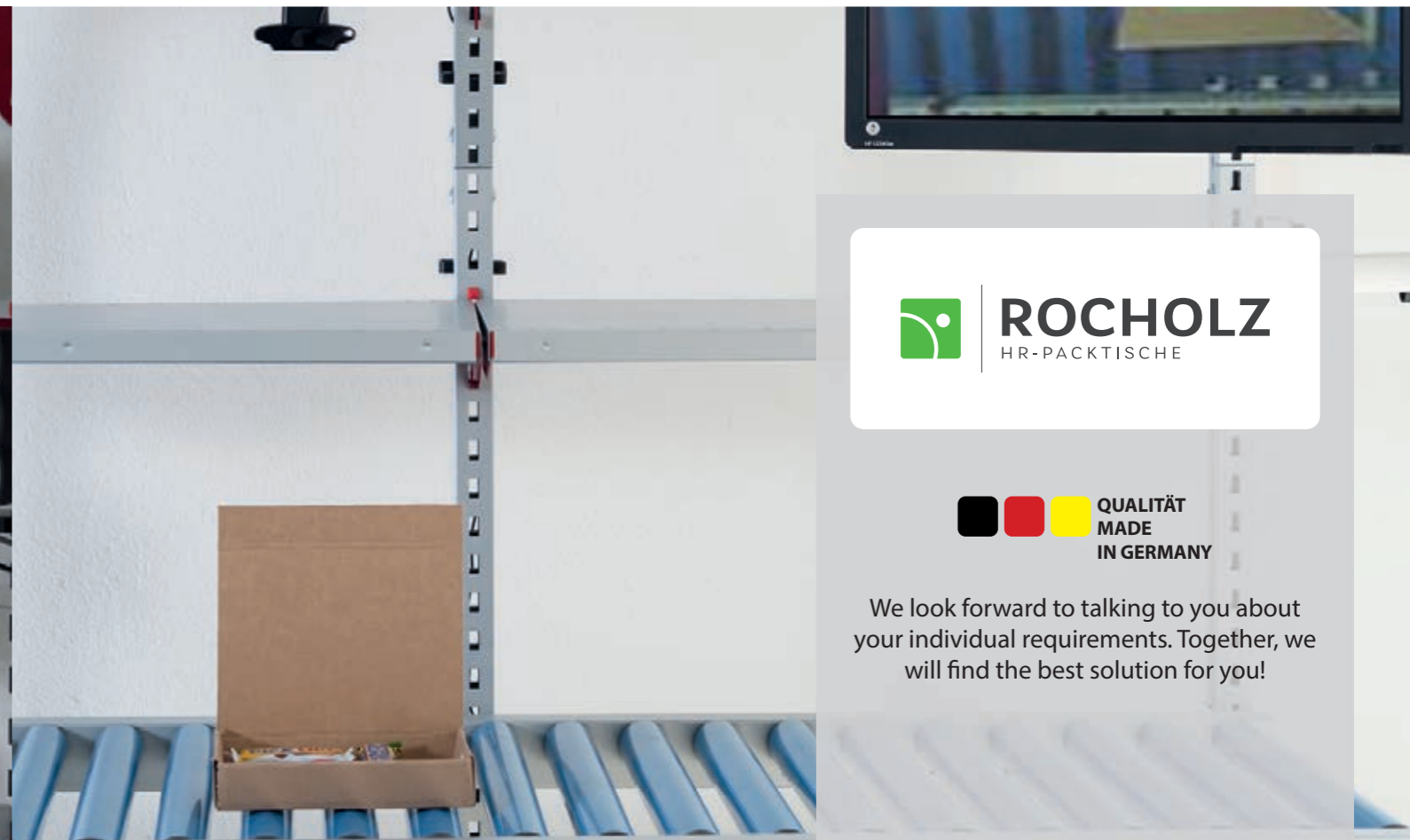

 **ROCHOLZ**
HR-PACKTISCHE

 **QUALITÄT
MADE
IN GERMANY**

We look forward to talking to you about your individual requirements. Together, we will find the best solution for you!

Individual solutions

Your Idea is Our Mission

The workplace plays a crucial but often underestimated role when it comes to productivity and optimising processes.

By effectively integrating workplaces into the flow of goods or considering downstream and upstream processes, it is possible to lower processing times and increase order picking and packing output by around 20%!

Together with the support of your local distributor, our dedicated department boasting years of extensive project experience aims to ensure that your packing workplaces are not only ideally integrated into product flow, but also satisfy and fulfil ergonomic standards.

**You have a project that requires an individual solution?
Don't hesitate to get in touch with us!**

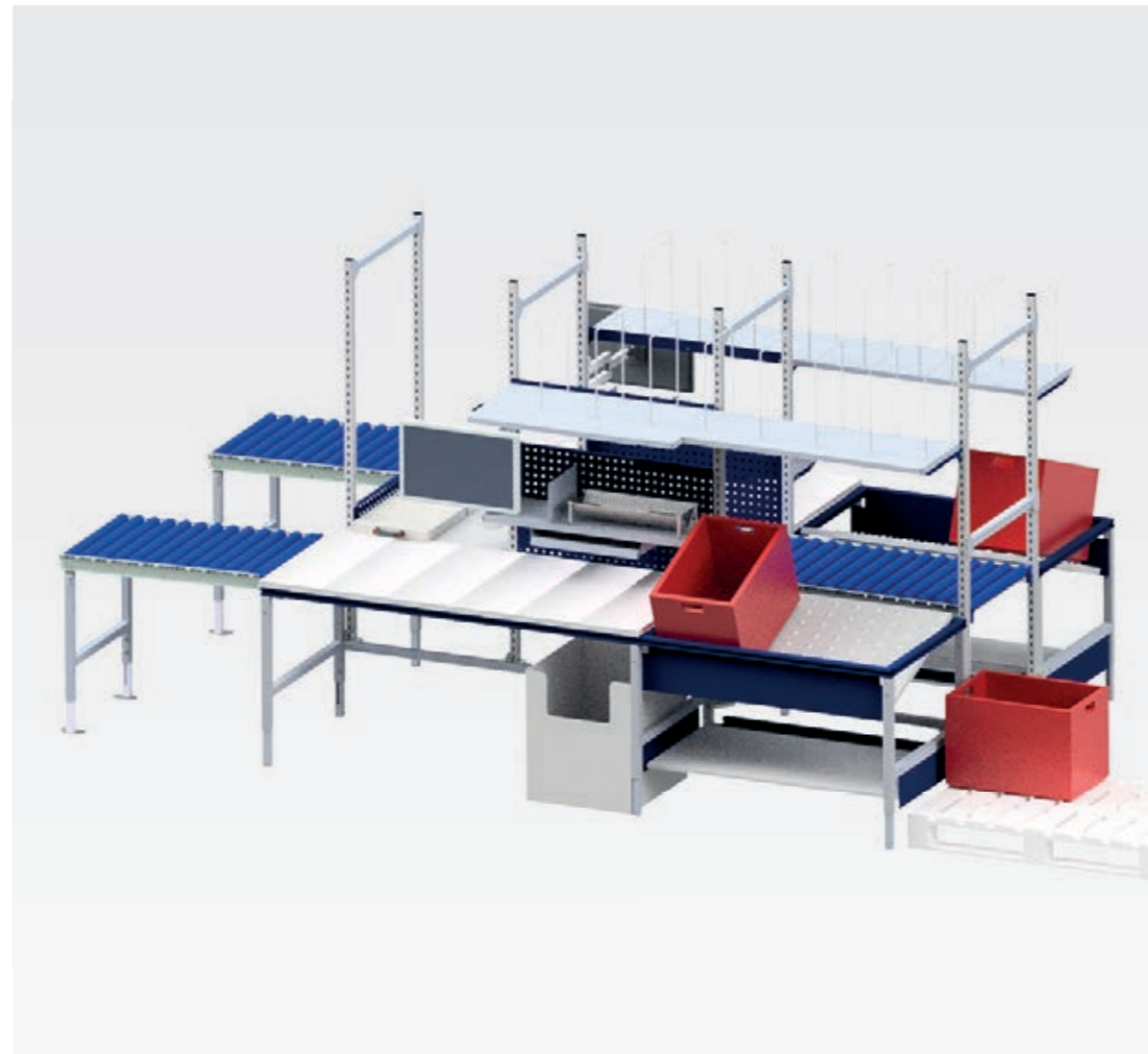
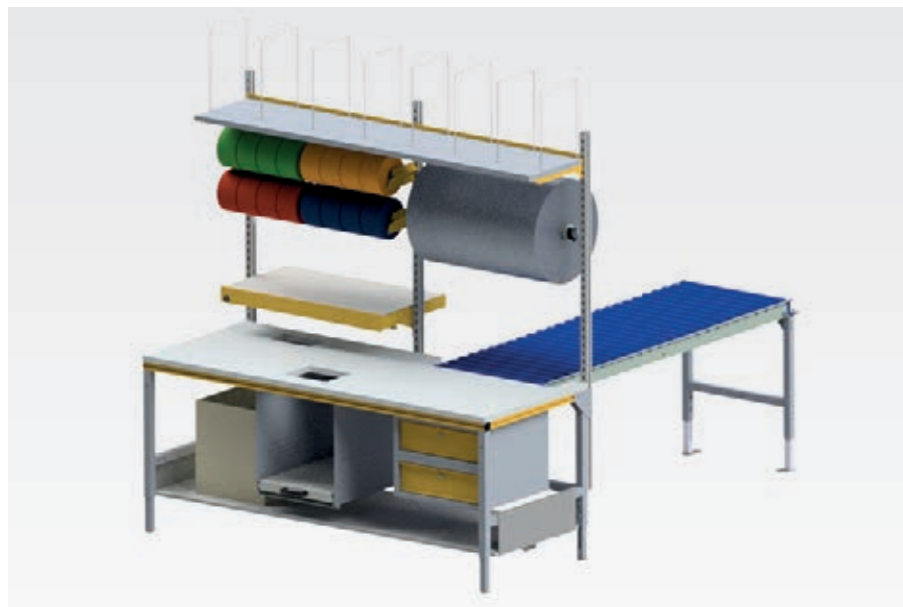
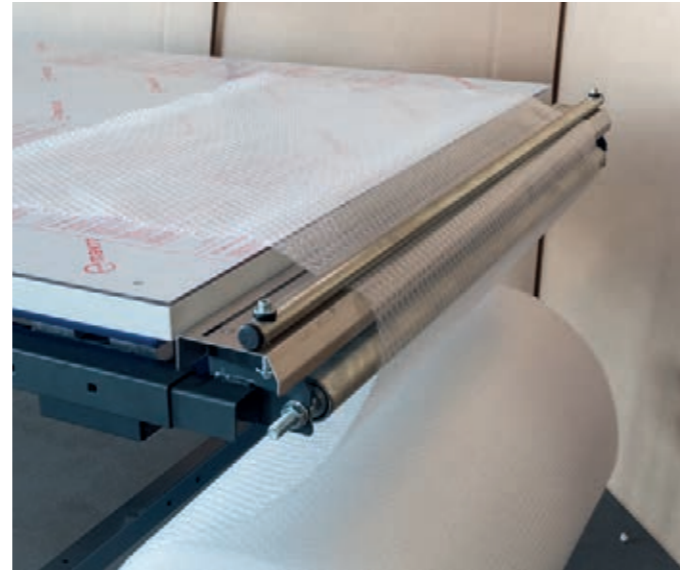

FANTASTIC

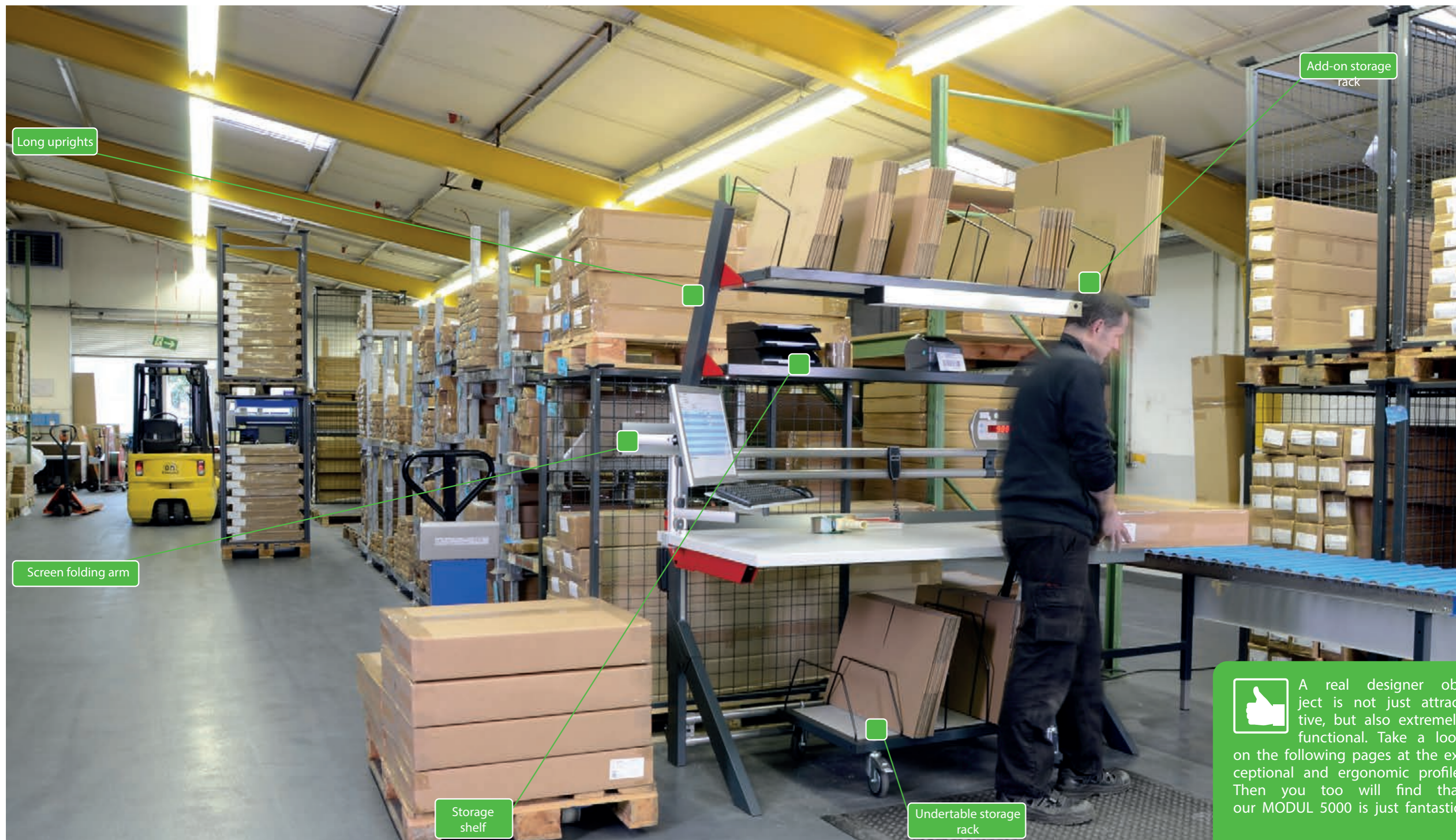

A real designer object is not just attractive, but also extremely functional. Take a look on the following pages at the exceptional and ergonomic profile. Then you too will find that our MODUL 5000 is just fantastic.

MODUL 5000



Take a look at our extensive range of accessories from page 80!



MODUL 5000

The design is exceptional, ergonomic, and has received international awards. Its intelligent construction enables even the basic configuration of the MODUL 5000 to be easily adapted to accommodate personal requirements for working seated or standing up. If required, the working level can also be adjusted using a crank mechanism, or for maximum convenience with an electric motor.

- Sturdy steel table
- Worktop 2000 x 880 x 38 mm
- 200 kg surface load capacity
- Light grey worktop, coated with melamine resin
- Steel components with powder-coated finish, anthracite RAL 7016, ruby red RAL 3003
- Simple height adjustment at 50 mm intervals (720-1070) without tools
- Optional height adjustment with a crank or electric motor
- Extensive range of accessories
- Tables with an integrated scale and/or roller track

 QUALITÄT
MADE
IN GERMANY

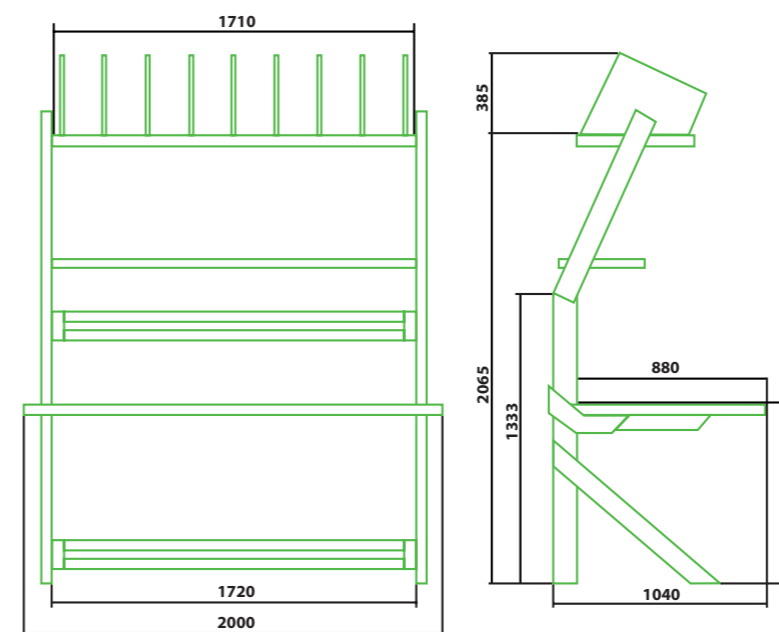

The MODUL 5000 is also ideal as an office workplace. Its "floating table top" means that there are no table legs to get in the way when you're sitting at it. The attractive design blends into every modern office landscape.

MODUL 5000



Maximalistic

The MODUL 5000 can also be equipped as a dual order picking and packing station. The top level serves as a cardboard storage rack, while the picking products are readily available underneath it on a slanting shelf. The counting scale integrated in the packing table features a PC interface as well as printer and scanner ports.

The integrated pneumatic lift table moves packing items weighing up to 60 kg and allows for effortless order picking or packing. The products are conveniently transported to the conveyor system over the roller track table standing next to the station. This prevents muscle and back ailments, a frequent cause of incapacity for work.

Ergonomics and design

The MODUL 5000 packing table with integrated roller track is a real highlight. The work surface made of galvanised sheet steel also offers enough space to "hold" even large cartons. The table height can be adjusted to between 770 and 1120 mm. This enables you to integrate it in your order picking and packaging processes.

- Ergonomic intersection for an uninterrupted flow of goods
- Integrated roller track
- Height adjustment at 50 mm intervals (720-1070)
- Optional height adjustment with a crank or electric motor
- Exceptional and ergonomic design
- Ergonomic positioning of the accessories by means of the inclined uprights

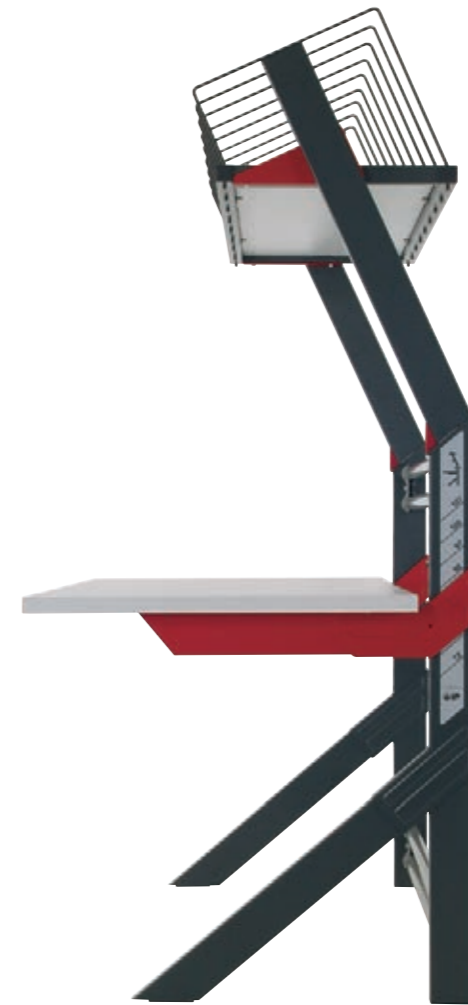
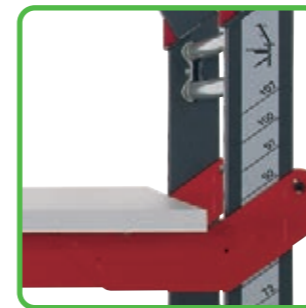

The tables from the MODUL 5000 programme have an adjustable height of 720-1070 mm: manually at 50 mm increments, or infinitely with a crank or electric motor!

MODUL 5000

Special features at a glance:

- An exceptional and ergonomic design that has received international awards.
- Can be quickly and easily adapted to accommodate personal requirements for working seated or standing up. The working level can also be adjusted as required with a crank mechanism or electric motor.
- The modular system can be expanded and adapted for new requirements whenever necessary with elements from the extensive range of accessories. This assures you long-term security for your investment.
- Also available in combination with an integrated scale and roller track.
- With MODUL 5000, we and our distribution partners can also offer you custom solutions for your own requirements.

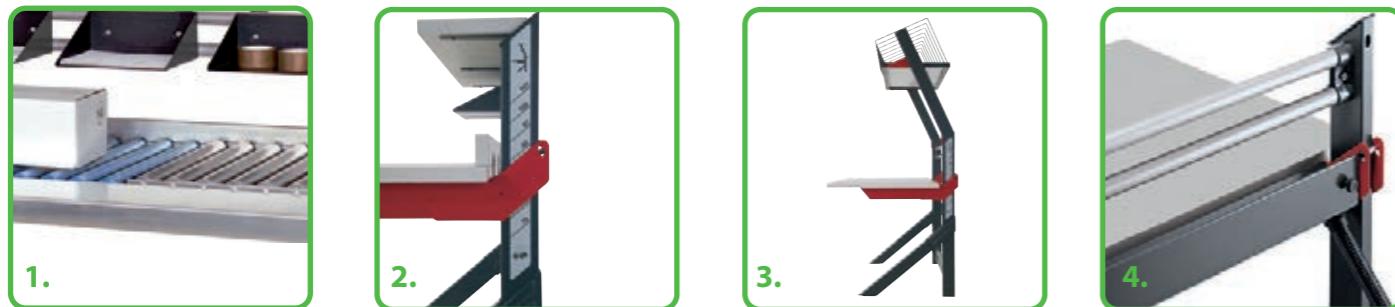

Alongside high quality standards, being located in Germany also means that we can guarantee short delivery times and efficiently supply accessories and spare parts.

Basic MODUL 5000



- MODUL 5000 packing and work table**
- Base frame and table support arms made of 100 x 40 mm tubular steel
 - 38 mm table top, height adjustable at 50 mm intervals (720-1070 mm)
 - Laminated with light grey plastic, with non-reflecting surface and rounded edges
 - Max. surface load 200 kg

Order no.	W x D x H (mm)
503000	2000 x 1040 x 1330

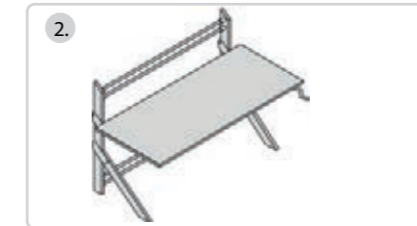

- MODUL 5000 packing and work table**
- Base frame and table support arms made of 100 x 40 mm tubular steel
 - 38 mm table top, height can be adjusted using insertable crank (720-1070 mm)
 - Laminated with light grey plastic, with non-reflecting surface and rounded edges
 - Max. surface load 200 kg

Order no.	W x D x H (mm)
503500	2000 x 1040 x 1330



- MODUL 5000 packing and work table**
- Pushbutton-controlled, infinitely variable height adjustment 720-1070 mm, with cable duct
 - Max. load when adjusting 100 kg
 - Electrical connection 230 V, 50 Hz
 - Max. surface load 200 kg
 - Speed of lifting system 12 mm/sec.

Order no.	W x D x H (mm)
503800	2000 x 1040 x 1330

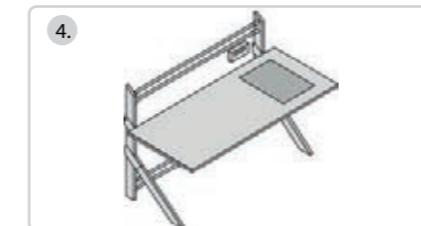

- Packing and work table with scale**
- With integrated calibrating digital carton scale
 - For max. 60 kg, incl. PC interface
 - Scale division 20g
 - Stainless steel platform
 - With separate display unit
 - Max. load capacity of lifting system 200 kg
 - Speed of lifting system 12 mm/sec.

Order no.	W x D x H (mm)
503042 Height adjustment at 50 mm intervals 770-1120 mm	2000 x 1040 x 1330
503552 Height adjustment with crank 770-1120 mm	2000 x 1040 x 1330
503852 Electric height adjustment: 770-1120 mm	2000 x 1040 x 1330



- Roller track table with work surface**
- Height adjustment at 50 mm intervals (770-1070)
 - Packing table with integrated roller track
 - Roller width 600 mm
 - Work surface 1955 x 251 mm
 - Made of galvanised sheet steel
 - Design as for table 503000
 - Compatible with accessories for MODUL 5000
 - Max. load capacity of lifting system 200 kg
 - Speed of lifting system 12 mm/sec.

Order no.	W x D x H (mm)
503010 Height adjustment at 50 mm intervals 770-1120 mm	1955 x 1040 x 1330
503510 Height adjustment with crank 770-1120 mm	1955 x 1040 x 1330
503810 Electric height adjustment: 770-1120 mm	1955 x 1040 x 1330



- Roller track table with work surface**
- With integrated digital carton scale for max. 60 kg, calibrated
 - With separate display unit
 - Supplied with interface cable
 - Work surface 1955 x 251 mm, made of galvanised steel
 - Roller width 600 mm, spacing 75 mm, diameter 50 mm
 - Base frame and table support arms made of 100 x 40 mm tubular steel
 - Max. load capacity of lifting system 200 kg
 - Speed of lifting system 12 mm/sec.

Order no.	W x D x H (mm)
503012 Height adjustment at 50 mm intervals 770-1120 mm	1955 x 1040 x 1330
503512 Height adjustment with crank 770-1120 mm	1955 x 1040 x 1330
503812 Electric height adjustment: 770-1120 mm	1955 x 1040 x 1330



End stop for roller track

Order no.	W x D x H (mm)
203541	600 x 10 x 100

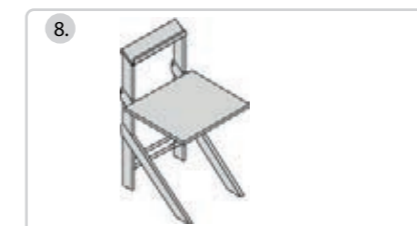

- Equipment stand**
- Adjustable height 570-1070 mm
 - Height adjustment at 50 mm intervals
 - 38 mm table top
 - Max. load capacity 100 kg

Order no.	W x D x H (mm)
5090	800 x 840 x 1330

Accessories above the table MODUL 5000

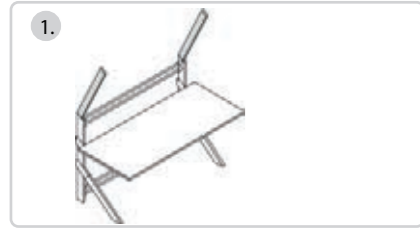

Uprights

- For attachment to the top table extensions
- With perforations for attaching various shelves
- Different levels
- Weight 8 kg

Order no.	W x D x H (mm)
5064	40 x 95 x 950

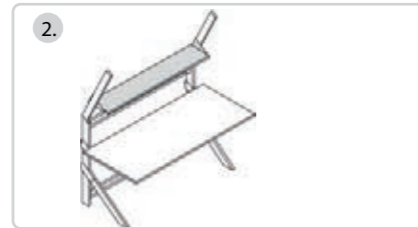

Storage shelf

- For packing materials, forms, etc.
- For attachment in the perforations in the top upright
- Max. surface load 70 kg
- Steel frame with shelf
- Weight 18 kg

Order no.	W x D x H (mm)
505000	1705 x 400



Storage shelf

- For mounting on tubular cross members
- Max. surface load 50 kg
- Weight 17 kg

Order no.	W x D x H (mm)
5051	1705 x 295

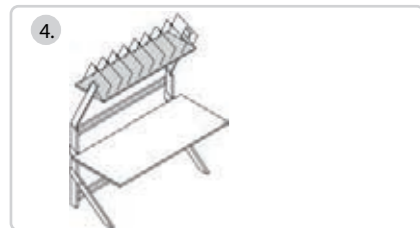

Add-on storage rack

- With 9 steel wire dividers
- For attachment at varying heights in the perforations of the top upright
- Max. surface load 100 kg
- Space for approx. 160 folding cartons
- Weight 28 kg

Order no.	W x D x H (mm)
505300	1705 x 550 x 40

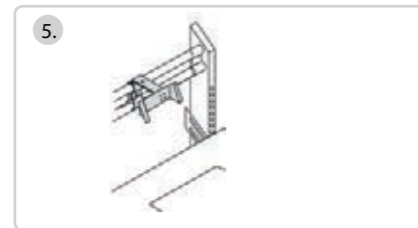

Bracket for scale display unit

- For mounting on tubular cross members
- Weight 1 kg

Order no.	W x D x H (mm)
5091	120 x 92 x 42



Workplace lighting

- For mounting under storage rack (505300)
- LED with dimming function

Order no.	W x D x H (mm)
207003	976 x 51 x 54 32W 1409 LUX
207004	661 x 51 x 54 21W 903 LUX
507001 Holder for attaching the workplace lighting	1720 x 40 x 40

Accessories on and underneath the table MODUL 5000



Backboard

- For rear confinement on the table top
- Material as for table top 503000
- Simple clamp attachment to the rear edge
- Weight 4 kg

Order no.	W x D x H (mm)
5060	1705 x 85



Cable duct

- With screw-mounted cover and flexible plastic cable guide
- Only for table 503000
- Not for use with article 5035xx

Order no.	W x D x H (mm)
5075	1680 x 155 x 185



Lockable drawer

- For use on right and left underneath table
- Plastic guide rail with drawer stop
- Load capacity 20 kg
- Weight 8 kg

Order no.	W x D x H (mm)
5006	475 x 570 x 100

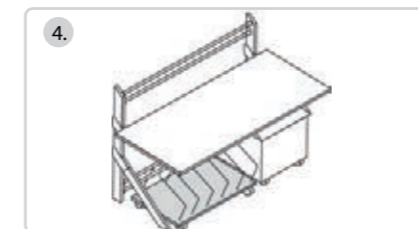

Undertable storage rack, short

- Mobile and lockable
- 6 steel wire dividers
- Space for approx. 100 folding cartons
- Max. surface load 50 kg
- Weight 20 kg

Order no.	W x D x H (mm)
5042	1110 x 550 x 480



Undertable storage rack, long

- Mobile and lockable
- 9 steel wire dividers
- For approx. 160 folding cartons
- Max. surface load 50 kg
- Weight 32 kg

Order no.	W x D x H (mm)
5043	1705 x 550 x 480

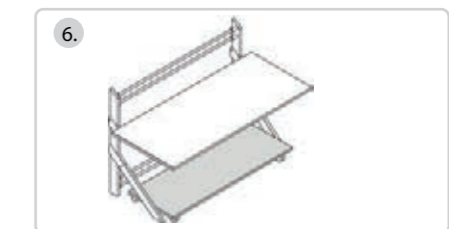

Bottom shelf

- Mobile with 4 lockable castors
- Max. surface load 50 kg
- Weight 33 kg

Order no.	W x D x H (mm)
5009	1600 x 700 x 100

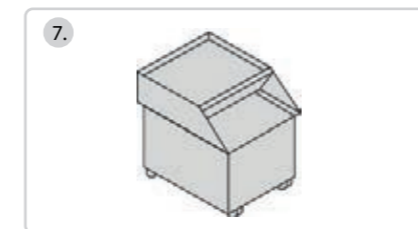

Container with drawer

- Mobile and lockable
- Drawer with lock and stopper
- For waste disposal
- Load capacity of container: 40 kg

Order no.	W x D x H (mm)
5008	555 x 760 x 665

IT accessories MODUL 5000



Support column with screw clamp

- For attaching a Screen folding arm and a keyboard tray
- Aluminium profile with clamp attachment

Order no.	W x D x H (mm)
509001 Clamping range mm 14-40	51 x 51 x 445 Weight 1.5 kg
509002 Clamping range 5-65 mm	51 x 51 x 445 Weight 2 kg
509006 Clamping range 5-65 mm	51 x 51 x 845 Weight 2,7 kg



Screen support carriage

- For flexible attachment of a screen to the support column
- Load capacity 12 kg
- Weight 1 kg

Order no.	W x D x H (mm)
509202	100 x 125 x 115



Screen folding arms

- For flexible attachment of a screen
- VESA 75/100 quick-release attachment

Order no.	W x D x H (mm)
509203 Load capacity 5 kg	100 x 455 x 115
509204 Load capacity 15 kg	100 x 455 x 200
509207 Load capacity 8 kg	100 x 455 x 200 branch (456-704mm)



4-socket outlet

- Incl. 2.90 m connecting cable
- Weight 1 kg

Order no.	W x D x H (mm)
5074	61 x 45 x 304



NEW

Tablet holder

- for attaching to screen folding arms
- for tablets from 7" to 10"
- clamping length 160 - 300 mm

Order no.	W x D x H (mm)
509214	



NEW

Platform with folding arm

- For flexible attachment to the HR mounting profile
- Shelf area 404 x 288 mm
- Load capacity 10 kg

Order no.	W x D x H (mm)
509213	404 x 589 x 120



Keyboard and mouse platform with folding arm

- For flexible attachment to the supporting column or adapter
- Shelf size: 640 x 172 mm
- Load capacity 10 kg
- Weight 1 kg

Order no.	W x D x H (mm)
509201	640 x 728 x 120



NEW

Retractable keyboard tray

- extendable mouse tray left or right
- minimum table top thickness 25 mm
- RAL 9006 white aluminium

Order no.	W x D x H (mm)
509318	300 x 565 x 100

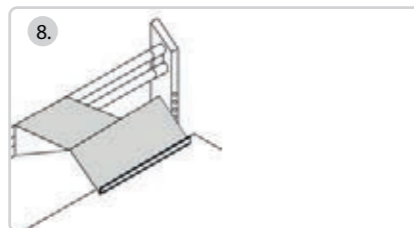

Keyboard tray

- Adjustable slanting tray with non-slip rubber coating
- For attachment to storage shelf 5050/5051 or multi-purpose tray 5081
- Weight 8 kg

Order no.	W x D x H (mm)
5085	420 x 570

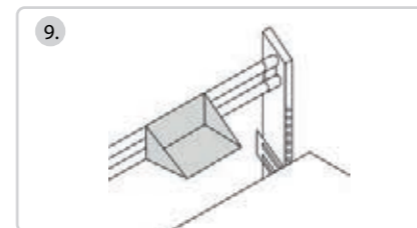

Multi-purpose tray

- For mounting on tubular cross members
- Load capacity 15 kg
- Weight 3 kg

Order no.	W x D x H (mm)
5081	315 x 240 x 130



Ergonomic workplace mat

- Protects the joints and spinal discs
- Bevelled edges for less risk of tripping
- Anti-slip surface

Order no.	W x D x H (mm)
600004 Dry version	1350 x 1000 x 16 Weight 19 kg
600005 Wet version	1350 x 1000 x 16 Weight 18 kg

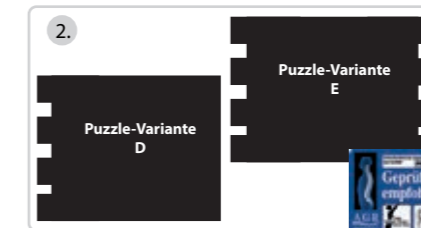

Ergonomic workplace mat

- Puzzle joint
- Protects the joints and spinal discs
- Bevelled edges for less risk of tripping
- Anti-slip surface

Order no.	W x D x H (mm)
600007 Puzzle variant D	1300 x 1000 x 16 Weight 30 kg
600009 Puzzle variant E	1240 x 1000 x 16 Weight 15 kg

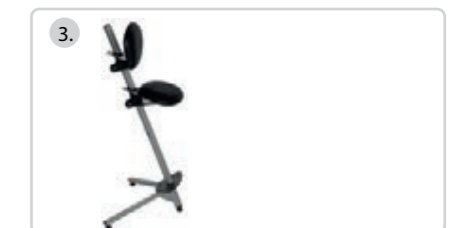

ErgoPlus 3000 standing aid

- Incl. foot rest
- Infinite adjustment of the seat cushion
- Collapsible
- Weight 12 kg

Order no.	W x D x H (mm)
519192	670 x 500 x 1100



Saddle stool

- Ergonomic saddle seat
- Seat tilt adjustment
- Adjustment range 630-890 mm
- Weight 10 kg

Order no.	W x D x H (mm)
852086	478 x 445 x 660



Footrest

- With inclined tread surface

Order no.	W x D x H (mm)
5185	470 x 370 x 120



Footrest

- Variable height 110-320 mm
- Moveable plastic tread plate
- Adjustable angle: 0°-30°
- Weight 7 kg

Order no.	W x D x H (mm)
852038	520 x 375 x 140



- Packing and order picking trolley**
- Height adjustment with gas pressure cylinder
 - Max. load capacity 30 kg
 - Weight 52 kg
 - Max. load capacity of lifting system 30 kg

Order no.	W x D x H (mm)
209040	700 x 800 x 700-920



- Pneumatic lift table**
- Allows effortless lifting and lowering of heavy cartons
 - Requires 6 bar compressed air supply
 - 250 mm lift height
 - Max. load capacity 60 kg
 - Weight 50 kg
 - Speed of lifting system 160 mm/sec.

Order no.	W x D x H (mm)
209100	600 x 600 x 500-710



NEW

- Mobile electric lift table**
- height adjustment via electric motor
 - with three working height memory positions
 - mobile with 4 swivel castors
 - incl. battery pack
 - max. load capacity 60 kg
 - max. load capacity of lifting system 80 kg
 - speed of lifting system 38 mm/sec.

Order no.	W x D x H (mm)
209050	700 x 800 x 554-854



- Pneumatic lift table, stainless steel platform**
- Stainless steel platform WxD 450 x 600 mm
 - Lift 500 mm
 - Incl. foot switch
 - Table prepared for bolting to floor
 - Mounting materials not included
 - Requires 6 bar compressed air supply
 - Max. load capacity 60 kg
 - Speed of lifting system 160 mm/sec.

Order no.	W x D x H (mm)
209101 Lift height 200-700 mm	450 x 735 x 1275
209102 Lift height 200-900 mm	450 x 735 x 1675



NEW

- Stationary electric lift table**
- height adjustment via electric motor
 - with three working height memory positions
 - max. load capacity 60 kg
 - max. load capacity of lifting system 80 kg
 - speed of lifting system 38 mm/sec.

Order no.	W x D x H (mm)
209051	700 x 800 x 540-840



- Pneumatic lift table, stainless steel platform**
- Stainless steel platform WxD 450x600 mm
 - Lift 500 mm resp. 700 mm
 - Incl. foot switch
 - Table with pedestal base
 - Requires 6 bar compressed air supply
 - Max. load capacity 60 kg
 - Speed of lifting system 160 mm/sec.

Order no.	W x D x H (mm)
209103 Lift height 250-750 mm	450 x 845 x 1320
209104 Lift height 250-950 mm	450 x 840 x 1720

Other accessories MODUL 5000

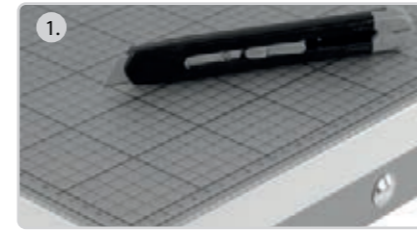

- Cut-resistant overlay**
- Transparent
 - For traceless cuts
 - Surface with slight anti-slip effect

Order no.	W x D x H (mm)
509400	900 x 600 x 3 Weight 2 kg



- Slice - Auto-Retractable Box Cutter**
- Incl. one double-sided ceramic blade
 - Automatically retractable blade
 - 8-10 times sharper than a steel blade
 - Easy blade change
 - Injury-proof handling

Order no.	W x D x H (mm)
99090238	



- Display panel holder with magnetic attachment**
- Display panel holder with 5 display panels, black
 - Metal wall holder with magnetic back

Order no.	W x D x H (mm)
591401	



- Cut-resistant overlay**
- Protects parts of the worktop against damage from mechanical strain
 - Bonded to worktop with the supplied adhesive pads

Order no.	W x D x H (mm)
203095 Stainless steel	1000 x 800 x 1 Weight 13 kg
203096 Galvanised sheet steel	1000 x 800 x 2 Weight 12 kg



- Solo Lift Pro carry aid**
- Practical, single-handed lifting aid for small, light boxes

Order no.	W x D x H (mm)
99090233	



- Display panel holder as table stand-up display**
- Complete set made of powder-coated steel for table top use
 - L-shaped, metal table stand-up display with 10 display panels, assorted colours

Order no.	W x D x H (mm)
557000	



- Reservoir made of PP cavity sheeting**
- Mould and moisture-proof
 - For hygienic applications, no fibre formation on the surface
 - Shock-absorbing
 - Set = 2 pcs.

Order no.	W x D x H (mm)
2056	600 x 500 x 600



- Dual Lift Pro carry aid**
- With 2 belt pouches
 - Safe lifting of large and heavy cartons through effective load distribution

Order no.	W x D x H (mm)
99090234	



- A4 display panel**
- 5 display panels
 - Polypropylene display panels with black all-round profile frame
 - For DIN A4 info sheets

Order no.	W x D x H (mm)
560601	

MODUL 5100 MODUL 5200

QUALITÄT
MADE
IN GERMANY



Mobile hanging frame

- 360° swivel mounting

Order no.	W x D x H (mm)
2046	1050 x 700 x 2100-3500 Weight 45 kg
802045	Weight 2 kg



Mobile cardboard storage rack

- Two levels
- With handle

Order no.	W x D x H (mm)
2042-2	1015 x 600 x 1260 Weight 42 kg
2043-2	1600 x 600 x 1260 Weight 58 kg



Mobile cardboard storage rack

- Three levels
- With handle

Order no.	W x D x H (mm)
2042-3	1015 x 600 x 1860 Weight 64 kg
2043-3	1600 x 600 x 1860 Weight 88 kg



Whether as a QM station, workshop trolley, standing workplace or mobile information stand, these two systems are extremely versatile just like all our other products. The mobile version is delivered with 4 castors (2 lockable).

Basic MODUL 5100



Standing/seating workplace, complete

- Comprising:
 - Standing table, max. load capacity 200 kg
 - Storage shelf, top, max. load capacity 50 kg
 - Drawer, load capacity 20 kg
 - Storage shelf, bottom, max. load capacity 50 kg
 - Multi-purpose shelf, load capacity 15 kg
 - Runners
 - Weight 85 kg

Order no.	W x D x H (mm)
510010	800 x 750 x 1330



ErgoPlus 3000 standing aid

- With infinite adjustment of the backrest and seat cushion 600-900 mm
- Collapsible
- Weight 10 kg
- max. load 110 kg

Order no.	W x D x H (mm)
519192	670 x 500 x 1100

Basic MODUL 5200



Standing workplace / QM station

- With information board
- Metal shelf and tray for small utensils
- Max. surface load of shelf 50 kg
- Load capacity of drawer 35 kg
- Weight 53 kg

Order no.	W x D x H (mm)
531003	670 x 650 x 1765



Standing workplace / QM station

- With information board
- Metal shelf and drawer for suspension files
- Max. surface load of shelf 50 kg
- Load capacity of drawer 35 kg
- Weight 53 kg

Order no.	W x D x H (mm)
531004	670 x 650 x 1765



Standing workplace / QM station

- With information board
- Metal shelf and filing cabinet
- Max. surface load of shelf 50 kg
- Load capacity of cabinet 35 kg
- Weight 46 kg

Order no.	W x D x H (mm)
531005	670 x 650 x 1765



Standing workplace / QM station

- With information board
- Metal shelf and tray for small utensils
- Max. surface load of shelf 50 kg
- Load capacity of drawer 35 kg
- Weight 65 kg

Order no.	W x D x H (mm)
531007	1050 x 650 x 1765



Standing workplace / QM station

- Wide with table top
- Metal shelf and information board
- Max. surface load per drawer 50 kg
- Weight 51 kg

Order no.	W x D x H (mm)
531001	1050 x 650 x 1765



Standing workplace / QM station

- Narrow with whiteboard incl. pen set
- Metal shelf and filing cabinet
- Max. surface load of shelf 50 kg
- Load capacity of cabinet 35 kg
- Weight 46 kg

Order no.	W x D x H (mm)
531009	670 x 650 x 1765



Mobile packing station

- Narrow, mobile, two-sided
- With wide wooden shelf, metal shelf and add-on storage rack

Order no.	W x D x H (mm)
531010N	1050 x 1060 x 1800
527109 VESA 75/100 holder for screen	610 x 282

Cutting systems

For better cutting results

Choose from our proven and tested cutting systems with dispenser for roll material (such as paper, cardboard or foil) for use either as a stand-alone cutting station or right next to the packing workplace.

The machinery quickly pays for itself since roll material is cheaper than cuttings. Not only that, but it also makes the dangerous and time-consuming handling of knives and scissors superfluous.

We supply two cutter cartridges - as standard!



QUALITÄT
MADE
IN GERMANY



The cutter cartridges can be exchanged without any effort. The round cutter for paper, cardboard, etc., the blade for all soft foil. A clamping mechanism allows comfortable insertion of the material and safe holding after every cut.

Cutter stand, horizontal

Diameter of the axle tube for all articles 32 mm, core diameter 60 - 85 mm



Cutter stand, horizontal

- Dispensing height 890 mm
- Max. roll weight 200 kg
- Max. roll Ø 1000 mm

Order no.	Cutting width mm	W x D x H (mm)
55307	750	1090 x 970 x 1060
55310	1000	1340
55312	1250	1590
55316	1600	1940



Dual cutter stand

- Dispensing height 890/1215 mm
- Max. weight per roll 150 kg
- Max. roll Ø 750 mm

Order no.	Cutting width mm	W x D x H (mm)
55407	750	1090 x 970 x 1740
55410	1000	1340
55412	1250	1590
55416	1600	1940



Undertable cutter

- Mobile
- Dispensing height 580 mm
- Max. roll weight: 200 kg
- Max. roll Ø 750 mm

Order no.	Cutting width mm	W x D x H (mm)
25507	750	1000 x 880 x 740
25510	1000	1250
25512	1250	1500
25516	1600	1850



Cutter stand, horizontal

- For light rolls
- Infinitely adjustable dispensing height
- Max. roll weight 100 kg
- Max. roll Ø 800 mm

Order no.	Cutting width mm	W x D x H (mm)
26207N	750	1120 x 850 x 1165
26210N	1000	1370
26212N	1250	1620
26216N	1600	1970
26218N	1800	2170
26220N	2000	2370



Cutter stand, for 2 rolls

- For light rolls
- Infinitely adjustable dispensing height
- With one cutter
- Max. total roll weight 130 kg
- Max. roll Ø 800 mm

Order no.	Cutting width mm	W x D x H (mm)
26507	750	1120 x 850 x 1665
26510	1000	1370
26512	1250	1620
26516	1600	1970
26518	1800	2170
26520	2000	2370



Dual cutter stands

- For light rolls
- Infinitely adjustable dispensing height
- With two cutters
- Max. total roll weight 130 kg
- Max. roll Ø 800 mm

Order no.	Cutting width mm	W x D x H (mm)
26407	750	1120 x 850 x 1665
26410	1000	1370
26412	1250	1620
26416	1600	1970
26418	1800	2170
26420	2000	2370



Undertable cutter, mobile

- Dispensing height 544 mm
- Max. roll weight 200 kg
- Max. roll Ø 750 mm

Order no.	Cutting width mm	W x D x H (mm)
55507	750	1090 x 970 x 810
55510	1000	1340
55512	1250	1590
55516	1600	1940

Cutters, wall-mounted and table version



Mounting materials not included

Wall-mounted cutter:

- Spindle Ø 32 mm
- Max. roll weight: 80 kg
- Max. roll Ø: 250 mm

Order no.	Cutting width mm	W x D x H (mm)
25907	750	1000 x 375 x 428
25910	1000	1250
25912	1250	1500
25916	1600	1850



Table top cutter:

- Spindle Ø 32 mm
- Max. roll weight: 80 kg
- Max. roll Ø: 250 mm

Order no.	Cutting width mm	W x D x H (mm)
25607	750	1000 x 341 x 340
25610	1000	1250
25612	1250	1500
25616	1600	1850

Wall-mounted cutter:

- Spindle Ø 32 mm
- Max. roll weight: 200 kg
- Max. roll Ø: 500 mm

Order no.	Cutting width mm	W x D x H (mm)
26007	750	1000 x 645 x 559
26010	1000	1250
26012	1250	1500
26016	1600	1850

Table top cutter:

- Spindle Ø 32 mm
- Max. roll weight: 200 kg
- Max. roll Ø: 500 mm

Order no.	Cutting width mm	W x D x H (mm)
25707	750	1000 x 582 x 465
25710	1000	1250
25712	1250	1500
25716	1600	1850

Cutter stand, vertical



Cutter stand, vertical

- Max. roll weight: 200 kg
- Max. roll Ø 450 mm

Order no.	Cutting width mm	W x D x H (mm)
35010	1000	480 x 563 x 1295
35012	1250	1545
35016	1600	1895



Cutter stand, vertical

- Max. roll weight: 200 kg
- Max. roll Ø 800 mm

Order no.	Cutting width mm	W x D x H (mm)
35110	1000	800 x 880 x 1295
35112	1250	1545
35116	1600	1895
35118	1800	2095
35120	2000	2295

Roll dispensers and add-on cutter



Mobile roll dispenser

- Max. roll weight: 200 kg
- Max. roll Ø 750 mm

Order no.	Roll width mm	W x D x H (mm)
53107	750	1090 x 770 x 680
53110	1000	1340
53112	1250	1590



Mobile roll dispenser

- Max. roll weight: 200 kg
- Max. roll Ø 750 mm
- 4 castors, of which 2 are lockable

Order no.	Roll width mm	W x D x H (mm)
23207	750	1000 x 840 x 500
23210	1000	1250
23212	1250	1500



Mobile roll dispenser

- Max. roll weight: 200 kg
- Max. roll Ø 500 mm
- 4 castors, of which 2 are lockable

Order no.	Roll width mm	W x D x H (mm)
23107	750	1000 x 600 x 400
23110	1000	1250
23112	1250	1500

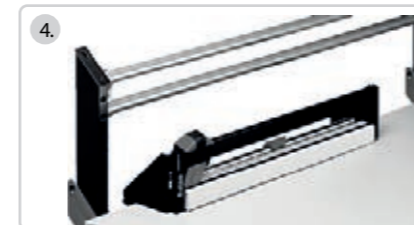

Add-on cutter

- Max. clamping range 70 mm
- Suitable for SYSTEM 2000 and 503000

Order no.	Cutting width mm	W x D x H (mm)
55107	750	1033 x 250 x 280
55110	1000	1283
55112	1250	1533
55116	1600	1883

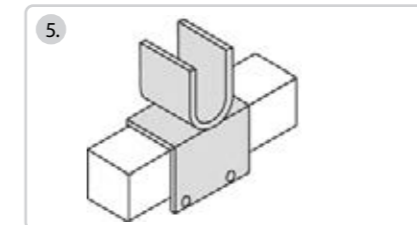

Bearing shells for roll spindles

- For undertable installation SYSTEM 2000
- Horizontal
- Weight 0.5 kg

Order no.	W x D x H (mm)
23800	



Spindle set, complete

- Spindle tube diameter 32 mm, for roll widths up to 1600 mm
- 1 pair of cones for core diameters 60 - 85 mm
- 2 clamp rings for adjusting the roll
- Incl. for tables with a clear width of 1640 mm
- Weight 3 kg
- for attachment to the table, art. 23800 is additionally necessary

Order no.	W x D x H (mm)
23900	1850 x 32 mm Ø

Cutter stand accessories

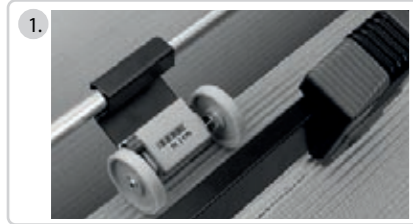

Metre counter

- Suitable for cutter stands 262, 264, 265, 553, 554

Order no.	Roll width mm	W x D x H (mm)
256075	750	1000 x 155 x 155
256100	1000	1250
256125	1250	1500
256160	1600	1850
256180	1800	2050
256200	2000	2250



Roll stand with tear-off mechanism

- For pre-perforated material
- Castors not included
- Max. roll weight 100 kg
- Max. roll Ø 800 mm

Order no.	Roll width mm	W x D x H (mm)
26207 AV	750	1120 x 920 x 1165
26210 AV	1000	1370
26212 AV	1250	1620
26216 AV	1600	1970
26218 AV	1800	2170
26220 AV	2000	2370



Add-on winding unit

- Incl. hand crank
- Spindle and cones for core diameters 46 - 60 mm

Order no.	Suitable for
252507	26207N / 26407 / 26507
252510	26210N / 26410 / 26510
252512	26212N / 26412 / 26512
252516	26216N / 26416 / 26516
252518	26218N / 26418 / 26518
252520	26220N / 26420 / 26520



Roll runners for devices 553...

- With 4 castors, 2 of which are lockable

Order no.	W x D x H (mm)
5554 roll runners for devices 553... Load capacity per roll 75 kg	52 x 650 x 100 Weight 3 kg



Swivel castors for cutter stand

- 1 sales unit = 4 pcs (2 of these lockable)
- plastic red/black
- roll diameter 75 mm

Order no.	W x D x H (mm)
23601 Castors for devices 262..., 265..., 264... With 4 castors, 2 of which are lockable Load capacity per roll 70 kg	Weight 1 kg

Pneumatic cutter

The pneumatically powered cutter is used solely for cutting packing materials such as paper, tissue paper, kraft paper, corrugated cardboard, anti-rust paper, soft flat film, foam sheets, air bubble film, tubular film, etc.

Foam sheets can have a maximum thickness of 6 mm, air bubble film 10 mm.

Special and kraft paper with a grammage of more than 180 g/m² have to be tested for their cutting suitability. This also applies for flat and tubular film with a thickness of over 0.2 mm.



- Safe usage and ergonomic handling, especially for large cutting widths
- Consistent cutting quality
- Low fatigue, even for greater volumes, practicable for large widths (up to 1600 mm cutting width)



Pneumatic cutter stand, horizontal

- Compressed air connection 6 bar (max.)
- Max. roll weight: 200 kg
- Max. roll Ø 750 mm

Order no.	Cutting width mm	W x D x H (mm)
57310	1000	1730 x 970 x 1060
57312	1250	1980
57316	1600	2330



Pneumatic add-on cutter

- For rear edge of table
- Max. clamping range 70 mm
- 57112 is only suitable for 203000

Order no.	Cutting width mm	W x D x H (mm)
57112	1250	1980 x 235 x 200



The cutting speed is adjustable. Approx. 1.5 m/sec (factory setting)

Accessories for perforated back panels



Tool holder with oblique hook

- impact and scratch resistant
- coating stamped base plate 1,5mm
- „GS“ safety tested tool holder

Order no.	L x Ø (mm)
86000001	50 x 6
86000002	100 x 6
86000003	150 x 6
86000004	200 x 6



Tool holder with vertical hook end

- impact and scratch resistant
- coating stamped base plate 1,5mm
- „GS“ safety tested tool holder

Order no.	L x Ø (mm)
86000005	35 x 6
86000006	75 x 6
86000007	125 x 6



Tool holder with straight spike single

- impact and scratch resistant
- coating stamped base plate 1,5mm
- „GS“ safety tested tool holder

Order no.	L x Ø (mm)
86000008	50 x 6
86000009	100 x 6
86000010	150 x 6



Dual tool holder with oblique hook end

- impact and scratch resistant
- coating stamped base plate 1,5mm
- „GS“ safety tested tool holder system

Order no.	L x Ø (mm)
86000011	50 x 6
86000012	75 x 6
86000013	150 x 6



Dual tool holder with vertical hook end

- impact and scratch resistant
- coating stamped base plate 1,5mm
- „GS“ safety tested tool holder system

Order no.	L x Ø (mm)
86000014	35 x 6
86000015	50 x 6
86000016	75 x 6
86000017	150 x 6



Dual tool holder with straight spike

- impact and scratch resistant
- coating stamped base plate 1,5mm
- „GS“ safety tested tool holder system

Order no.	L x Ø (mm)
86000018	50 x 6
86000019	100 x 6
86000020	150 x 6



Magnetic holder

- impact and scratch resistant
- coating stamped base plate 1,5mm
- „GS“ safety tested tool holder system

Order no.	Ø (mm)
86000021	40



Machine tool holder

- impact and scratch resistant
- coating stamped base plate 1,5mm
- „GS“ safety tested tool holder system

Order no.	Ø (mm)
86000022	40
86000023	60
86000024	80



Rounded holder

- impact and scratch resistant
- coating stamped base plate 1,5mm
- „GS“ safety tested tool holder system

Order no.	L x B (mm)
86000025	65 x 25

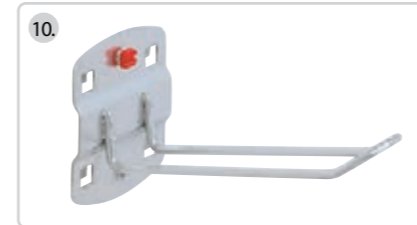

Tool holder for self-service packaging

- impact and scratch resistant
- coating stamped base plate 1,5mm
- „GS“ safety tested tool holder

Order no.	W x D (mm)
86000026	125 x 30



Pipe bracket

- impact and scratch resistant
- coating stamped base plate 1,5mm
- „GS“ safety tested tool holder

Order no.	W x Ø (mm)
86000027	35 x 60
86000028	35 x 100

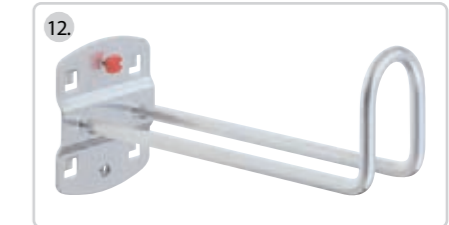

Cable holder with hookend 50mm

- impact and scratch resistant
- coating stamped base plate 1,5mm
- „GS“ safety tested tool holder

Order no.	W x D (mm)
86000029	100 x 37
86000030	150 x 37
86000031	200 x 37



Storage box

- impact and scratch resistant
- coating stamped base plate 1,5mm
- „GS“ safety tested tool holder

Order no.	W x D x H (mm)
86000032	320 x 135 x 55

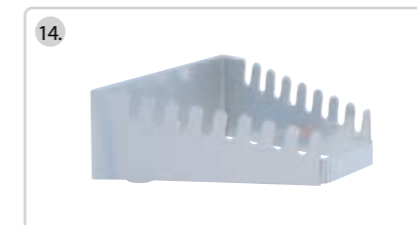

Spanner holder

- For 8 spanners
- impact and scratch resistant coating
- „GS“ safety tested tool holder system

Order no.	W x D x H (mm)
86000033	130/60 x 150 x 50

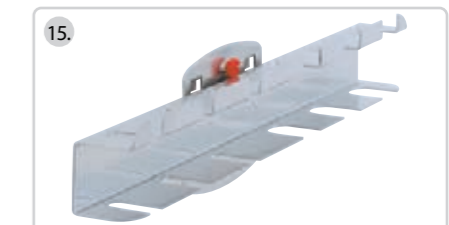

Screwdriver holder

- for 6 screwdrivers
- impact and scratch resistant coating
- „GS“ safety tested tool holder system

Order no.	W x D x H (mm)
86000034	200 x 30 x 40
86000035	390 x 30 x 40

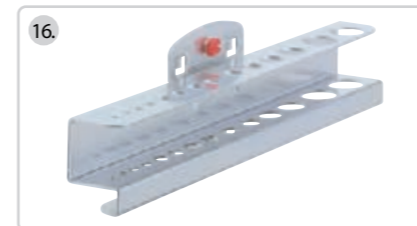

Drill/Allen key holder

- For 14 pieces various Ø
- impact and scratch resistant coating
- „GS“ safety tested tool holder system

Order no.	W x D x H (mm)
86000036	200 x 30 x 35
86000037	390 x 30 x 35

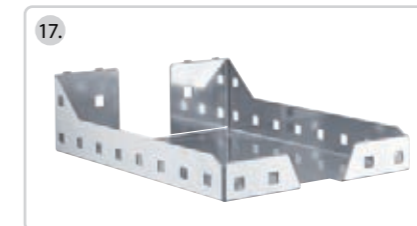

Document tray

- Impact and scratch resistant
- coating stamped base plate 1,5mm
- „GS“ safety tested tool holder system

Order no.	W x D x H (mm)
86000038	225 x 310 x 85

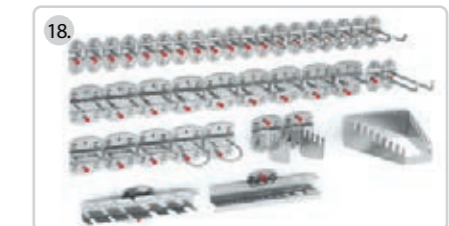

Tool holder set

- „GS“ safety tested tool holder system

Order no.	W x D x H (mm)
86000039	12 pieces
86000040	40 pieces



Open fronted storage boxes

- without holder
- 1 sales unit = 5 pcs

Order no.	W x D x H (mm)
704707	105 x 160 x 75



Adapter for open fronted storage boxes

- for attaching to a perforated back panel

Order no.	W x H (mm)
207010	550 x 58

For attaching accessories from this chapter, you will need the uprights or the mounting frame!

Hook range for perforated back panels on page 36



The patent turn: the genuine [®]RasterPlan screw made of polyamide protects the surface of the perforated back panel even after multiple changes in hanging position. [®]RasterPlan tool holders can easily be hung into the perforations and fixed by a screw turn, providing a secure hold.

TRANSPORTING SYSTEMS



TRANSPORTING SYSTEMS



- Warehouse trolley with handlebar**
- high-quality load area made of multiplex wood
 - wheels: 2 swivel castors and 2 fixed castors
 - TPE-tyres, 125 mm diameter, fitted on plastic rims

Order no.	load area	load capacity
600300	850x500 mm	300 kg
600301	1000x600 mm	300 kg



- Platform trolley with handlebar**
- high-quality load area made of multiplex wood
 - wheels: 2 swivel castors and 2 fixed castors
 - TPE-tyres, 125 mm diameter, fitted on plastic rims

Order no.	load area	load capacity
600302	850x500 mm	500 kg
600303	1000x600 mm	600 kg
600304	1000x700 mm	600 kg
600305	1200x800 mm	600 kg



- Platform trolley with mesh front panel**
- high-quality load area made of multiplex wood
 - wheels: 2 swivel castors and 2 fixed castors
 - TPE-tyres, 125 mm diameter, fitted on plastic rims

Order no.	load area	load capacity
600306	850x500 mm	500 kg
600307	1000x600 mm	600 kg
600308	1000x700 mm	600 kg
600309	1200x800 mm	600 kg



- Shelf trolley**
- high-quality load area made of multiplex wood
 - wheels: 2 swivel castors and 2 fixed castors
 - TPE-tyres, 125 mm diameter, fitted on plastic rims
 - 1460 mm height

Order no.	4 load areas	load capacity
600310	850x500 mm	500 kg
600311	1000x600 mm	600 kg
600312	1000x700 mm	600 kg
600313	1200x800 mm	600 kg



- Shelf trolley with two galvanised mesh panels**
- high-quality load area made of multiplex wood
 - wheels: 2 swivel castors and 2 fixed castors
 - TPE-tyres, 125 mm diameter, fitted on plastic rims
 - 1500 mm height

Order no.	4 load areas	load capacity
600314	850x500 mm	500 kg
600315	1000x600 mm	600 kg
600316	1000x700 mm	600 kg
600317	1200x800 mm	600 kg



- Parcel trolley**
- high-quality load area made of multiplex wood
 - wheels: 2 swivel castors and 2 fixed castors
 - TPE-tyres, 125 mm diameter, fitted on plastic rims
 - 1500 mm height

Order no.	load area	load capacity
600318	850x500 mm	500 kg
600319	1000x600 mm	600 kg
600320	1000x700 mm	600 kg
600321	1200x800 mm	600 kg



All of our transporting devices are characterised by their functionality and longevity. They are perfectly suited to supplement your logistics workplace effectively. Handlebars in RAL 3003 (ruby red), 5010 (gentian blue) and 7016 (anthracite gray).

ESD accessories

ESD (electrostatic discharge) is a form of discharge that can occur due to different voltages in all kinds of daily situations. This kind of discharge can cause damage to electronic parts that is often not even recognisable. Therefore, we offer conductive worktops and ESD accessories for picking and packaging sensitive electronic components, which prevent damage by means of said conductivity.

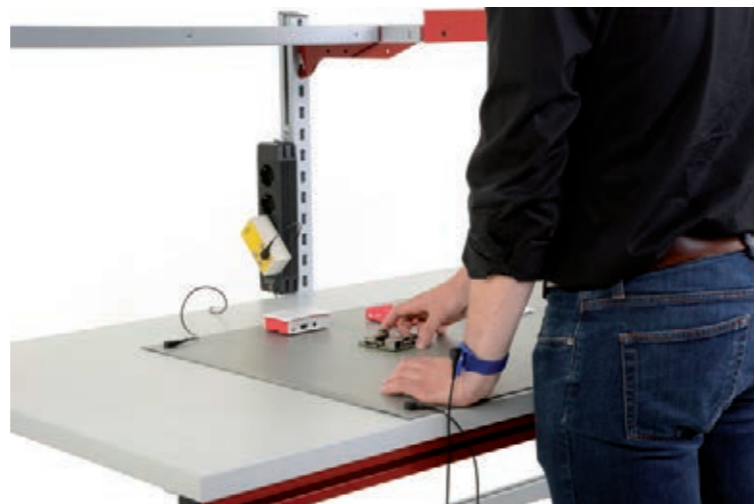

- Ergonomic workplace mat**
- ESD conductive in accordance, incl. connection cable
 - surface: ball-shaped nubs
 - colour: black
 - incl. connection set comprising ESD grounding cable, ESD drive-in nut, ESD push button, ESD screw M4X12, ESD screw M4X20

Order no.	W x D x H (mm)
99090215	1350 x 1000 x 16
86000101	1950 x 1000 x 16



- Wrist strap set**
- wrist strap
 - 10 mm snap + spiral cable
 - length: 2m, 10 mm – 10 mm snap

Order no.	W x D x H (mm)
99090242	1000 x 600 x 5



- ESD workplace set**
- mat for table with two snap connectors (10 mm, dimensions: 600 mm x 1000 mm; colour: grey)
 - wrist strap, 3 mm snap
 - spiral cable, length: 2m, 3 mm + 10 mm snap
 - EBP box (shockproof grounding plug) with 2 x 10 snap + 1 x safety socket
 - connection cable: mat for table – EBP box
 - identification label

Order no.	W x D x H (mm)
86000130	1000 x 600 x 10

On request we gladly offer packing and workplaces SYSTEM 2000, SYSTEM FLEX, MODUL 5000 with ESD table tops.

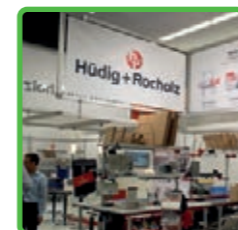

FachPack



FachPack

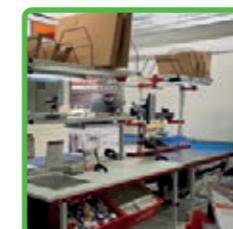

LogiMAT

Online configurator



Virtual showroom

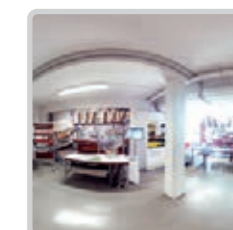

You can convince yourself about the quality of our products at trade exhibitions (upcoming dates can be found on our website) or your local dealer. Of course, you can also visit our showroom together with your dealer. We look forward to seeing you!

Comparison chart

	BASIC	SYSTEM 1200 / 1600	SYSTEM 2000	SYSTEM FLEX	SYSTEM FLEX LIGHT	MODUL 5000
Table width 1200		●		●		
Table width 1600	●	●		●	●	
Table width 2000	●		●	●		●
Table depth	800	800	920	800	800	880
Mounting profiles for accessories, straight	●	●	●	●	●	
Mounting profiles for accessories, ergonomically inclined				●		●
Variably positionable uprights				●		
Variably angled accessories				●	●	
Adjustable height		●	●	●		●
Height adjustment by crank		●	●			●
Height adjustment by motor		●	●	●	●	●
IGR certification „Ergonomic Product“				●		
Ergonomic accessories		●	●	●	●	●
Extensive range of accessories		●	●	●	●	●
Simple conversion /adaptation				●	●	
Special construction		●	●	●		●

